

---

User's Manual

**3561**

---

Battery Internal Resistance Meter



---

2021-01-28

Version V2.2

# Table of contents

Introduction .....	6
Checking Package Contents .....	6
Security information .....	8
Operating notes .....	10
<b>Chapter I Overview .....</b>	<b>14</b>
1.1 Introduction .....	14
1.2 Performance characteristics .....	15
1.3 Names of sections and summary of operations .....	16
1.4 Dimensions .....	20
1.5 Page composition.....	21
<b>Chapter II Preparation Before Testing .....</b>	<b>23</b>
2.1 Test flow preview .....	23
2.2 Basic parameter setting process .....	25
2.3 Inspection before measurement .....	26
2.4 Method for connecting test lines.....	27
<b>Chapter III Basic Provisions.....</b>	<b>29</b>
3.1 Set Test Range .....	29
3.2 Set Test Speed .....	31
3.3 Test Mode Settings.....	32
3.4 Trigger delay setting.....	33
3.5 Set test trigger source.....	34
3.6 Average number of times .....	35
3.7 Broadcast Mode Settings .....	36
3.8 Multiple test settings .....	37
3.9 System settings .....	38
3.9.1 Language settings .....	38
3.9.2 Power frequency settings .....	38

<b>Chapter IV Comparator Settings .....</b>	<b>40</b>
4.1 Comparator function .....	40
4.1.1 Open compare mode .....	40
4.1.2 Comparison of Results Signal Output Mode .....	40
4.2 Sorting function settings.....	41
4.2.1 Select the comparator settings interface.....	41
4.2.2 Select the relevant menu item .....	41
4.3 Response mode settings .....	45
4.4 Count settings .....	46
4.5 Absolute set .....	47
<b>Chapter V Measurement.....</b>	<b>48</b>
5.1 Start-up test .....	48
5.2 Measured value display .....	49
5.3 Zeroing .....	49
<b>Chapter VI Preservation of Measurement Panel .....</b>	<b>54</b>
6.1 Save Panel Settings .....	54
6.2 Call measurement settings .....	55
6.3 Save measurement data settings.....	55
6.4 Save Measurement Data Export .....	56
<b>CHAPTER VII EXT I/O Interface (Handler) .....</b>	<b>57</b>
7.1 EXT I/O ports and signals .....	57
7.1.1 Port signal details.....	59
7.1.2 Port Signal Connection Mode .....	62
7.2 Sequence diagram.....	63
7.2.1 Sequence diagram of external trigger .....	63
7.2.2 Read flow when triggered externally.....	64

<b>CHAPTER VIII Communications.....</b>	<b>66</b>
8.1 RS232 Communication Mode .....	66
8.1.1 Interface and Cable .....	66
8.1.2 RS232 Connection Mode .....	67
8.1.3 RS232 Communications Settings .....	67
8.2 RS485 Communication Mode .....	69
8.2.1 RS485 Connection Mode .....	69
8.2.2 RS485 Communications Settings .....	69
8.3 USB interface .....	71
<b>Chapter IX Parameters .....</b>	<b>72</b>
9.1 General parameters .....	72
9.2 Accuracy.....	73
<b>CHAPTER X SCPI Communication Instructions .....</b>	<b>74</b>
10.1 General instructions.....	74
10.2 SCPI Instruction Structure.....	75
10.3 SCPI sub-instruction system.....	76
<b>Chapter XI MODBUS Communications Directive .....</b>	<b>83</b>
11.1 Register Overview .....	83
11.1.1 Hold register .....	83
11.1.2 Input register .....	84
11.2 MODBUS instructions .....	85
11.2.1 Read hold register instruction (0x03) .....	85
11.2.2 Read input register instruction (0x04) .....	86
11.2.3 Write register instructions (0x10) .....	87
11.2.4 Trigger instrument test instructions (0x74) .....	88

## Introduction

Thank you for purchasing HT3561 Battery Tester. To obtain maximum performance from this product, please read this manual first, and keep it handy for future reference.

Registered trademarks

Windows and Excel are registered trademarks of Microsoft Corporation in the United States and/or other countries.

## Checking Package Contents

When receiving instrument, please check carefully to ensure that the instrument is not damaged during transit. In addition, special inspections of accessories, panel switches and connectors are required. If the instrument is found to be damaged or it fails to operate as described in the user manual, please contact us.

To transport this instrument, use the original packaging and wrap it in a double carton. Damage during transit is not covered by the warranty.

**Check the standard package contents as follows:**

No.	Item	Quantity
1	3561 Battery Tester	1
2	Test cable	1
3	RS232 communication cable	1
4	Power cord	1
5	User Manual	1

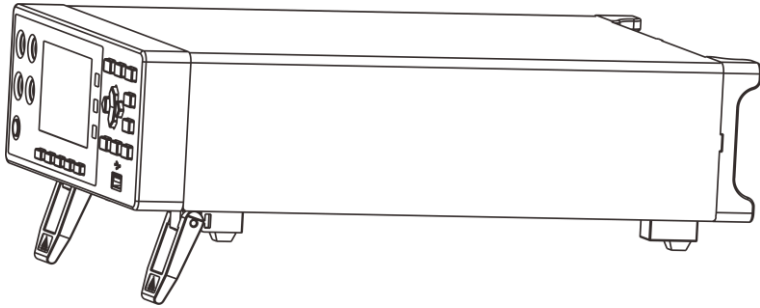

Battery Tester

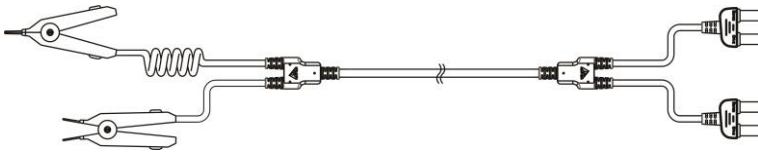

9363A Test cable

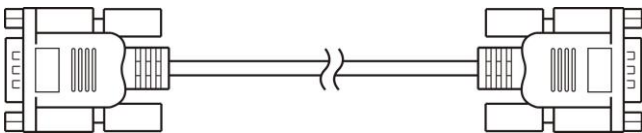





9800 RS232 communication cable

## Security information

The instrument is designed to conform to IEC 61010 Safety Standards, and has been thoroughly tested for safety prior to shipment. However, if it is used improperly, it may cause injury or death and damage the instrument. Be sure to read through this manual and its precautions before use. Our company does not assume any responsibility for accidents and injuries not caused by defects in the instrument itself.



## Safety Symbols

This manual contains information and warnings essential for safe operation of the instrument and for maintaining it in safe operating condition. Before using the instrument, be certain to read the following safety notes carefully.

	Indicates very important message in this manual. When the symbol is printed on the instrument, refer to a corresponding topic in the Instruction Manual.
	Indicates DC (direct current)
	Indicates a fuse
	Indicates earth terminal

In this manual, the risk seriousness and the hazard levels are classified as follows:

	Indicates an imminently hazardous situation that will result in death or serious injury to the operator.
---	--

 <b>WARNING</b>	Indicates a potentially hazardous situation that will result in death or serious injury to the operator.
 <b>CAUTION</b>	Indicates a potentially hazardous situation that may result in minor or moderate injury to the operator or damage to the instrument or malfunction.
 <b>NOTE</b>	Indicates functions of the instrument or relative suggestion of a correct operation.

## Accuracy

We define measurement tolerances in terms of f.s. (full scale), rdg. (reading) and dgt. (digit) values, with the following meanings:

f.s. (Maximum display value)

This is usually the maximum display value. In the instrument, this indicates the currently used range.

rdg. (Reading or displayed value)

The value currently being measured and indicated on the measuring instrument.

dgt. (Resolution)

The smallest displayable unit on a digital measuring instrument, i.e., the input value that causes the digital display to show a "1".



## Operating notes

### Environmental Considerations and General Inspection

#### Operating & Storage

- ✧ Operating temperature and humidity ranges  
0°C to 40°C 80%RH or less (no condensation)
- ✧ Storage temperature and humidity ranges  
23 ±5°C 80%RH or less (no condensation)

To avoid failure or damage to the instrument, do not place the tester in the following places:



- ✧ Places exposed to direct sunlight or high temperatures
- ✧ Places exposed to high humidity or condensation
- ✧ Places exposed to large amounts of dust particles
- ✧ Places exposed to water, oil, chemicals or solvents
- ✧ Places exposed to corrosive or combustible gases
- ✧ Places with strong electromagnetic fields or electromagnetic radiation
- ✧ Places where mechanical vibration is frequent

## Checking before use



Before using the instrument the first time, verify that it operates normally to ensure that no damage occurred during storage or shipping. If you find any damage, please contact us.

 <b>WARNING</b>	<p>Before using the instrument, check that the coating of the test leads or cables are not torn and that no metal parts are exposed. Using the instrument under such conditions could result in electrocution. Contact your authorized distributor or reseller in this case.</p>
--	--

## Use of instruments

 <b>DANGER</b>	<p>To avoid electric shock, do not disassemble the instrument electronic enclosure. There are high pressure and high temperature parts inside the instrument during operation.</p>
 <b>CAUTION</b>	<p>To avoid any damage to the instrument, avoid any vibration or shock during transport or handling. Pay particular attention to avoid collision caused by falling.</p>
 <b>NOTE</b>	<p>Be sure to turn the power off after using it.</p>

## Measurement precautions

 <b>DANGER</b>	<p>To avoid electric shocks and short circuits, the following procedures must be followed:</p> <p>Do not allow the instrument to get wet, and do not use it with wet hands. This may cause electric shock accident.</p> <p>Do not modify, disassemble, or repair the instrument. This may result in fire, electric shock accident, or injury.</p>
 <b>CAUTION</b>	<p>Do not place the instrument on an unstable or slanted surface. It may drop or fall, causing injury or instrument failure.</p> <p>To avoid any damage to the instrument, do not input voltage or current to any measuring terminal, TC terminal, or External I/O terminal.</p>

## Use of test leads and cables

 <b>DANGER</b>	<p>To avoid electrical shock accident, do not short test leads where voltage is applied.</p>
---	--



Do not use any test lead or temperature sensor other than the ones specified by our company. It may result in inaccurate measurement due to poor contact or other reasons.

To avoid damaging the cables, do not bend or pull the base of cables and the leads.

The ends of pin type leads are sharp. Be careful to avoid injury.

To avoid damage to the test leads, when plug/pull the test line, don't hold the cable but connector.

# Chapter I Overview

## 1.1 Introduction

3561 is a high-precision wide range, high-performance microprocessor-controlled battery resistance tester. The internal resistance range is  $0.01\text{ m}\Omega\sim 3.1\ \Omega$ , the minimum resolution is  $0.01\text{ m}\Omega$ , the maximum display is 32000. Voltage range is  $0.1\text{ mV}\sim 20\text{ V}$ , minimum resolution  $0.1\text{ mV}$ , maximum display 200000. 3561 series of instruments support multi-channel scanning test function, by adding our company's multi-channel scanning tester, you can simultaneously scan and measure multi-channel battery.

RS232/RS485/LAN, instrument has three communication interfaces and two communication instruction protocols. The instrument uses SCPI(Standard Command for Programmable Instrument) when using Ethernet and RS232 communications. When using RS485 communication, the instrument uses MODEBUS instruction protocol. Users can efficiently complete remote control and data acquisition functions and instrument networking.

3561 can be used to test a variety of lithium batteries, nickel-hydrogen batteries, nickel-cadmium batteries, button batteries, columnar batteries, soft-pack and so on.

## 1.2 Performance characteristics

### Appearance

- ◇ Display using 3.5-inch high-resolution TFT screen display, simple operation
- ◇ Small fuselage, powerful

### Excellent test performance

- ◇ 0.01m $\Omega$  minimum resolution of internal resistance
- ◇ 0.1mV minimum resolution of voltage

### Rapid testing

- ◇ A minimum test cycle of 15ms

### Four-terminal test

- ◇ High precision measurement of low internal resistance

### Rich interface configuration

- ◇ HANDLER interface
- ◇ RS-232 interface
- ◇ RS-485 interface
- ◇ U disk interface

### Power supply

- ◇ Power supply 100~256 V
- ◇ 50 Hz/60Hz power supply
- ◇ 10 W maximum power consumption

# 1.3 Names of sections and summary of operations

## Positive

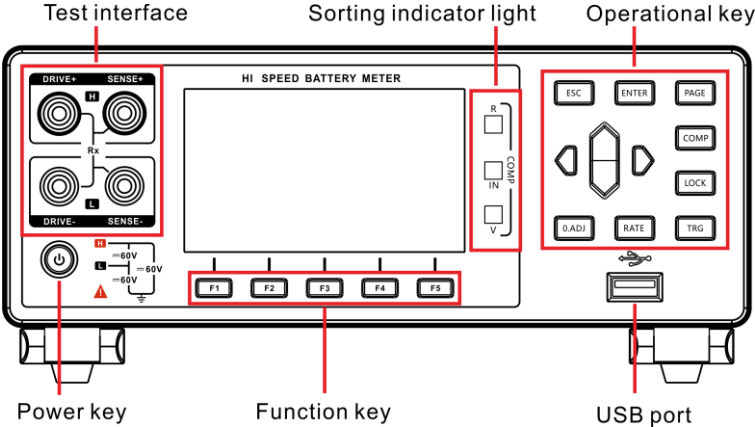

## Back view

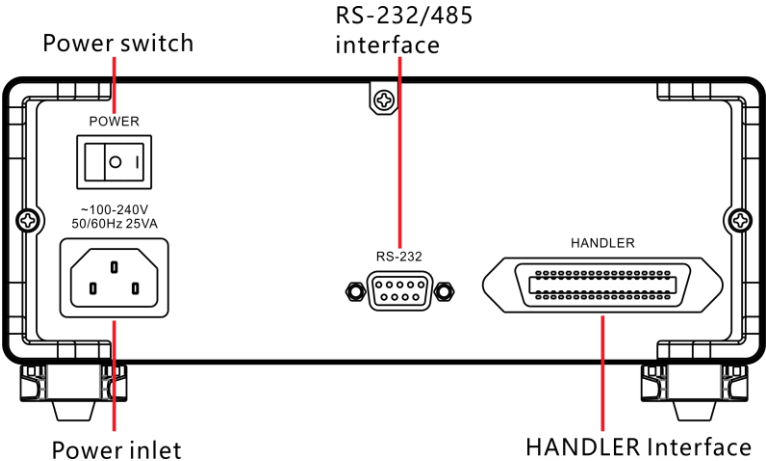

## Side

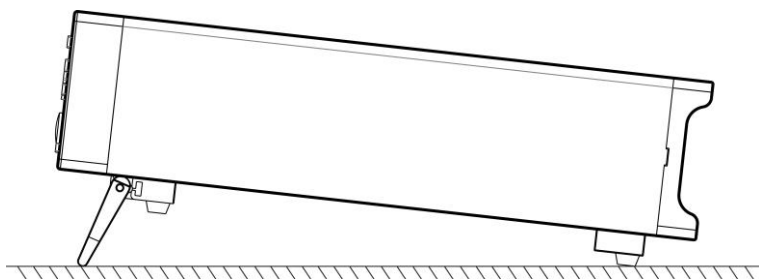



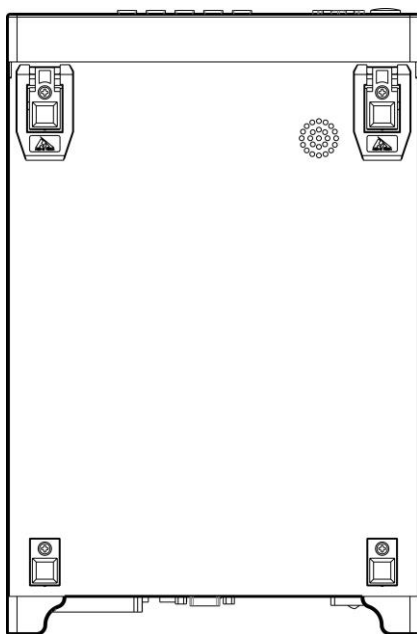











## Bottom





## Functional Buttons

Button	Function
	Functional key <b>F1</b>
	Functional key <b>F2</b>
	Functional key <b>F3</b>
	Functional key <b>F4</b>
	Functional key <b>F5</b>
	Function exit key
	Function determination key
	<a href="#">[Page Switching Key]</a> Switching <a href="#">[Test page]</a> <-> <a href="#">[Comparator page]</a> <-> <a href="#">[Setting page]</a> <-> <a href="#">[File page]</a>
	comparator on/off key

	<p>key lock key, short press [LOCK] key, lock page other key failure, long press can release lock</p>
	<p>[0.ADJ key], zeroing.</p>
	<p>[Speed key], set measurement rate.</p>
	<p>[Trigger key], single-trigger test of the instrument in manual trigger mode.</p>
	<p>[Direction key], used to select menu items or set values.</p>

## 1.4 Dimensions

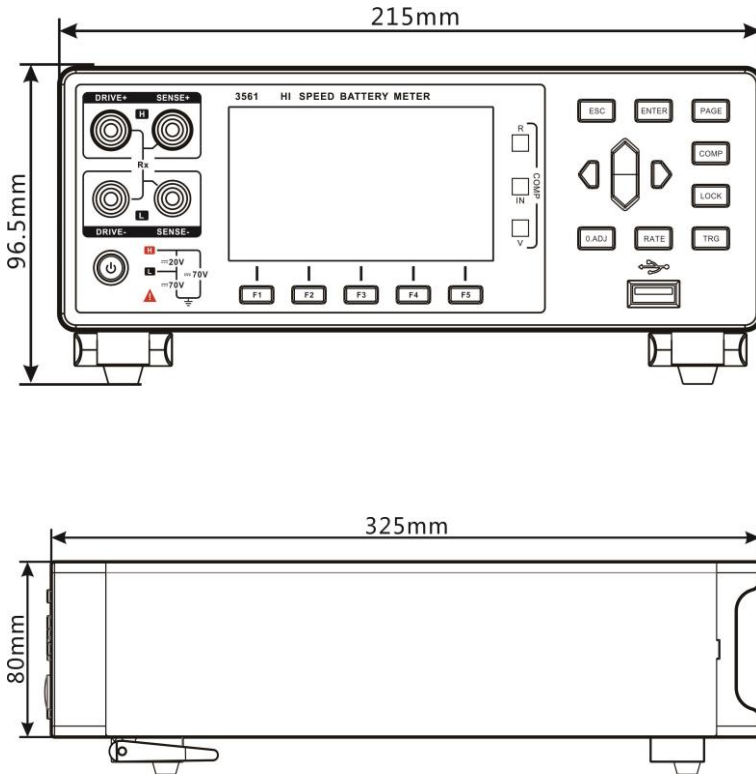

## 1.5 Page composition

### Measurement page

MEASURE		COMPARATOR	SETTING	FILE			
MODE	R-V	RATE	FAST	rRang	3m $\Omega$	vRANG	6V
LO	0.0000m $\Omega$	R: 1.0000 m $\Omega$ V: 1.00000 V					
HI	0.0000m $\Omega$						
LO	0.00000V						
HI	0.00000V						
rRang+	rRang-	vRang+	vRang-	AUTO			

### Comparator page

MEASURE		COMPARATOR	SETTING	FILE			
COMP	2	BEEP	GD	CNT	OFF	ABSOLU	OFF
R1	0.0000m $\Omega$	R2	1.0000m $\Omega$	R3	10.000m $\Omega$	R4	100.00m $\Omega$
V1	1.00000V	V2	2.00000V	V3	3.00000V	V4	4.00000V
2	3	4					

## Setting page

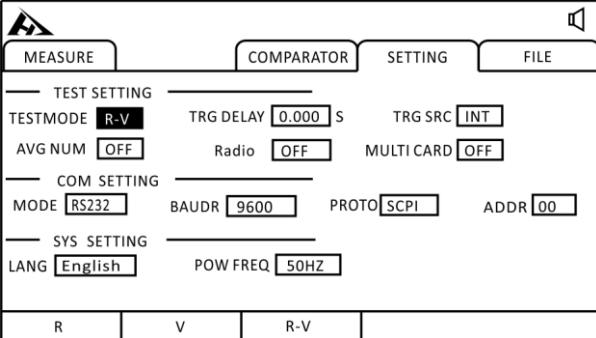

The screenshot shows a software interface with a top navigation bar containing 'MEASURE', 'COMPARATOR', 'SETTING', and 'FILE'. The 'SETTING' tab is active. Below the navigation bar, there are three sections: 'TEST SETTING', 'COM SETTING', and 'SYS SETTING'. Each section contains several parameters with their current values displayed in text boxes. At the bottom, there is a status bar with three columns: 'R', 'V', and 'R-V'.

TEST SETTING	
TESTMODE	R-V
TRG DELAY	0.000 S
TRG SRC	INT
AVG NUM	OFF
Radio	OFF
MULTI CARD	OFF

COM SETTING			
MODE	RS232	BAUDR	9600
PROTO	SCPI	ADDR	00

  

SYS SETTING	
LANG	English
POW FREQ	50HZ

R	V	R-V	
---	---	-----	--

## File page

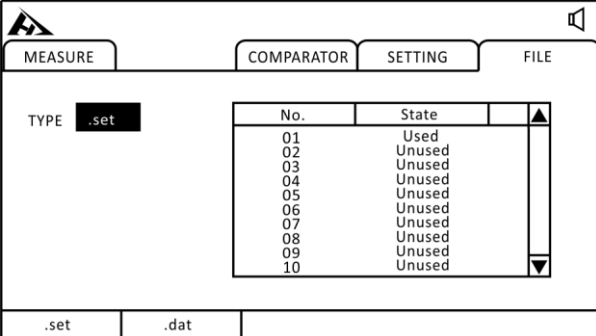

The screenshot shows a software interface with a top navigation bar containing 'MEASURE', 'COMPARATOR', 'SETTING', and 'FILE'. The 'FILE' tab is active. Below the navigation bar, there is a 'TYPE' field showing '.set'. To the right is a table with two columns: 'No.' and 'State'. The table lists file numbers from 01 to 10 and their corresponding states. At the bottom, there is a status bar with two columns: '.set' and '.dat'.

No.	State
01	Used
02	Unused
03	Unused
04	Unused
05	Unused
06	Unused
07	Unused
08	Unused
09	Unused
10	Unused

.set	.dat
------	------

# Chapter II Preparation Before Testing

## 2.1 Test flow preview

The instrument remains in the power off state, follow the following steps to prepare before testing.

1. turn off instrument power, connect test line

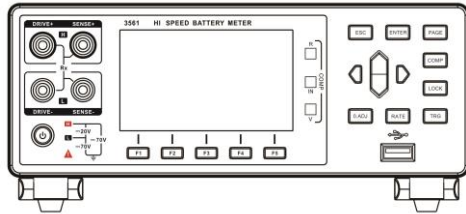
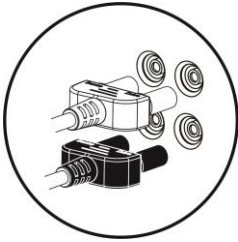

2. insert power cord

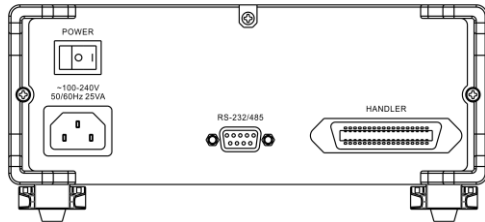
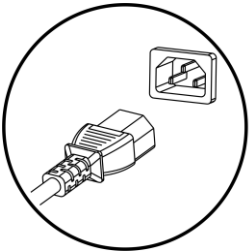

Ensure that the power line grounding is good, conducive to the stability of the test.

3. turn the power at the end of the instrument on

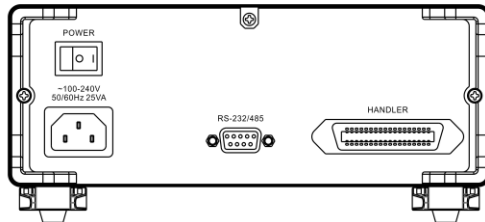
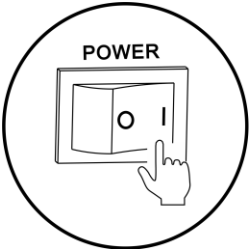

At this time, the internal power supply of the instrument has been connected, the instrument is in standby state.

- 4. press panel power button to turn on power

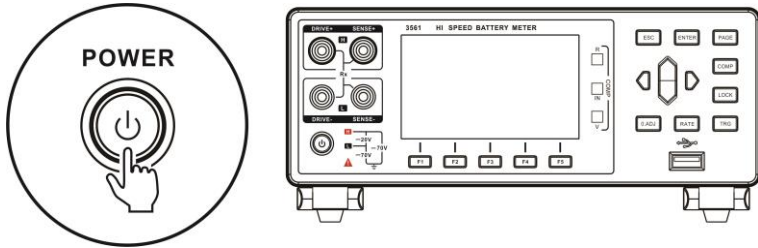

When in standby state, the panel power key lamp is red, press panel power key, power on, screen lit, panel key lamp turned green.

- 5. setting test parameters (see section 3.1 for details)

- 6. testing

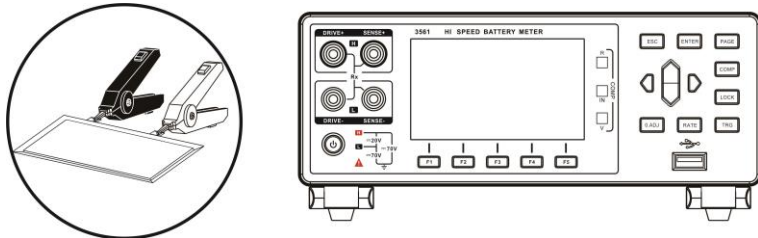

- 7. test is over, power off

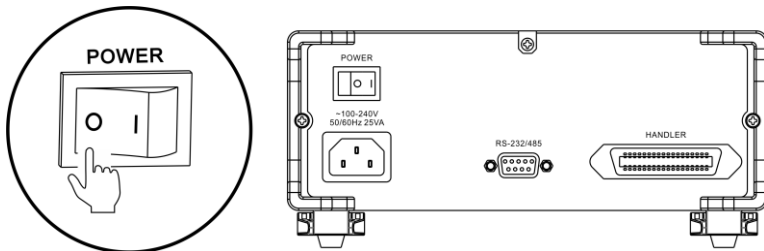

## 2.2 Basic parameter setting process

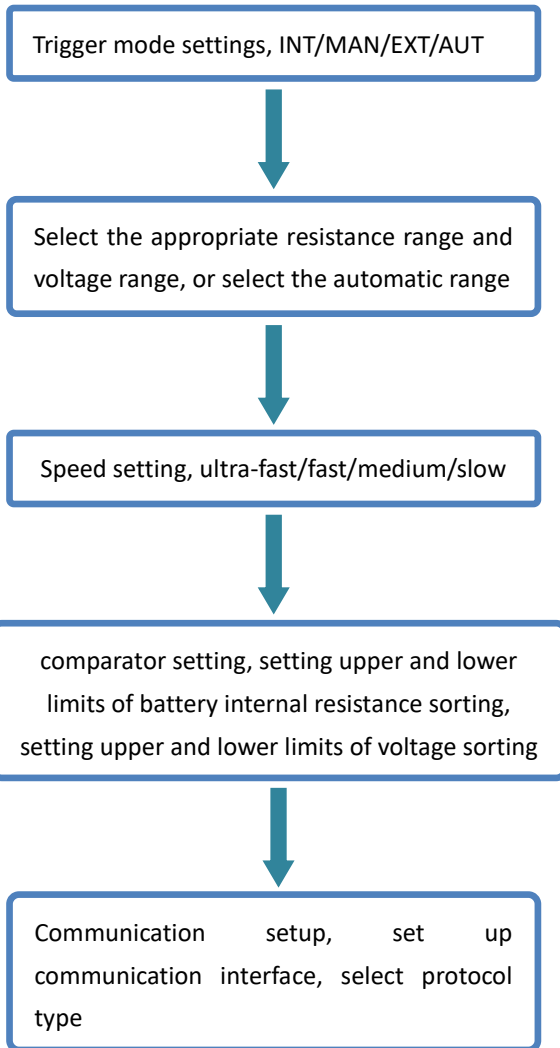



## 2.3 Inspection before measurement

Before use, please confirm that there is no failure caused by preservation and transportation, and then use after checking and confirming the operation. If you confirm that there is a fault, please contact our sales network.

### Confirmation of this instrument and peripheral equipment

Inspection projects	Processing methods
Is this instrument damaged or cracked? Is the internal circuit exposed?	Do not use it when it is damaged, please send it for repair.
Is metal sheet attached to the terminal and other garbage?	When attached, please wipe it with cotton swabs.
Is the outer skin of the test line damaged or metal exposed?	In case of damage, the measurement value may be unstable or error. It is recommended to replace the wire without damage.

### Confirmation of power on

Inspection projects	Processing methods
After the instrument tail power switch is turned on, observe whether the instrument panel power key lamp turns on?	Please confirm that the key lamp is on standby, otherwise please send it to repair.
When the power is turned on, is the screen all lit, and is the measurement screen normal?	Different display, may be the internal failure of this instrument, please send repair.

## 2.4 Method for connecting test lines

### Warning

- The test line port is sharp, be careful not to be scratched.
- For safety, the test line attached to the instrument should be used.
- To avoid electric shock, ensure that the test line is properly connected

### Front Panel Link

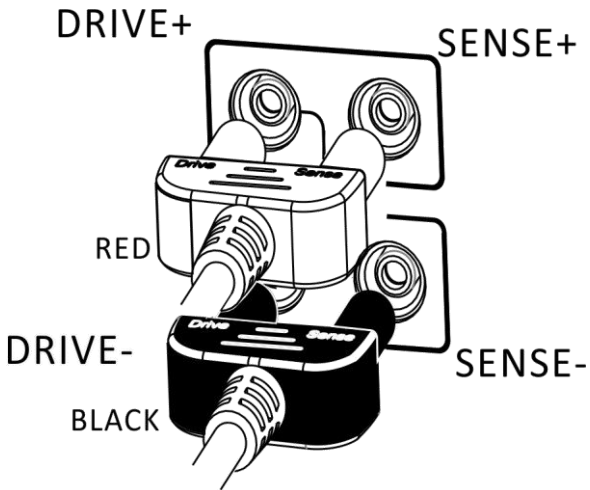

## test line connection

1.9363- A test clip test line (test soft pack battery)

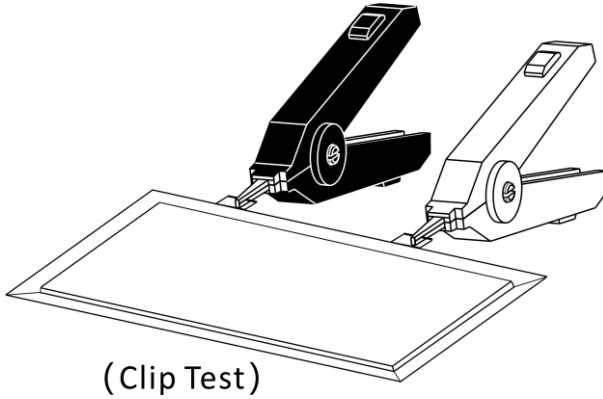

2.9363- B test probe test line

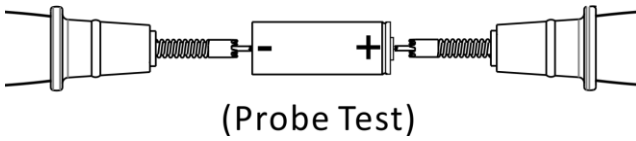

## Chapter III Basic Provisions

In order to use this instrument correctly, read this chapter before testing.

### 3.1 Set Test Range

Range setting is divided into manual range and automatic range. The automatic range instrument automatically selects a suitable range according to the battery under test.

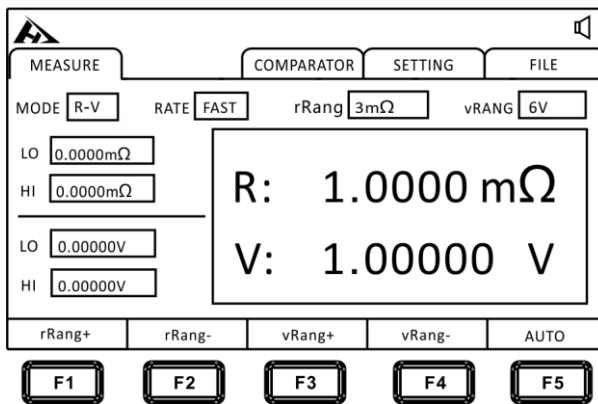

#### Manual range settings:

At the measurement interface, press the F1]-[F2] key to switch the range. Even when the automatic range function is turned on, the manual range switching is effective (when the automatic range is turned on, the automatic range function will automatically turn off when the manual range is switched on).

**Internal resistance range:**

**300mΩ↔3Ω**

### Automatic range setting:

At the measurement interface, press the [F3] key to switch the automatic range. When set to automatic range, [AUTO] mark lights up, turn off automatic range function, [AUTO] mark does not show.

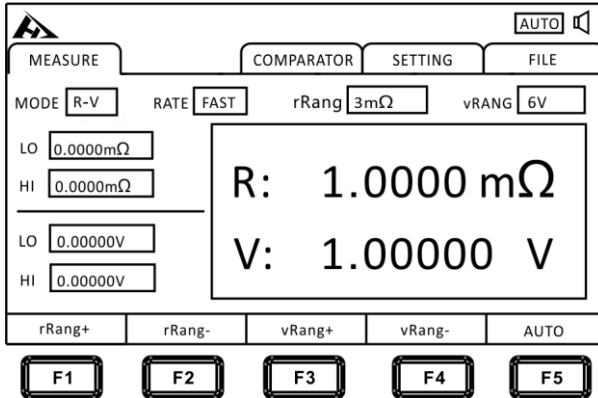

#### Note:

- If the range is changed in the state of automatic range opening, the automatic range is automatically removed and changed to manual range.
- The automatic range may become unstable because of the object under test. At this point, specify the range or extend the delay manually. For the test accuracy of each range, please refer to the "Measurement accuracy Table".

## 3.2 Set Test Speed

Press the [RATE] key on the test page to switch the current test speed. The ultra-fast sampling period is 66 times per second, the fast sampling period is 30 times per second, the medium speed sampling period is 10 times per second, and the slow sampling period is 3 times per second.

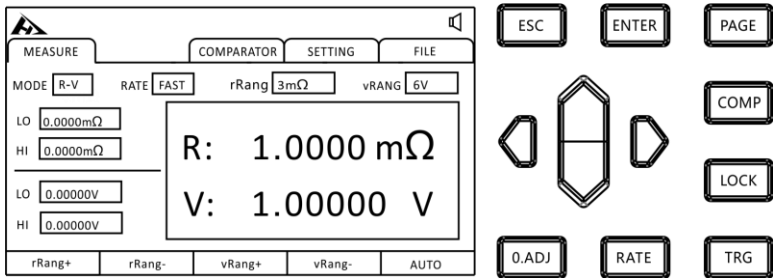

### Note:

- When the measurement delay is set, the sampling period becomes slower.
- Test time contains ADC sampling, sorting output and display time.
- In the test environment, the electric field interference is large, or the test is difficult to stabilize, it is recommended to use slow test.

### 3.3 Test Mode Settings

Click the [PAGE] key on the test page to switch to the settings page.

1. Select Parameter Settings Interface

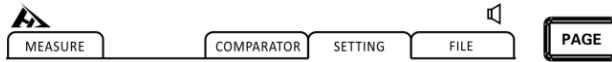

Press the [PAGE] key to select Parameter setting page

2. select relevant menu items

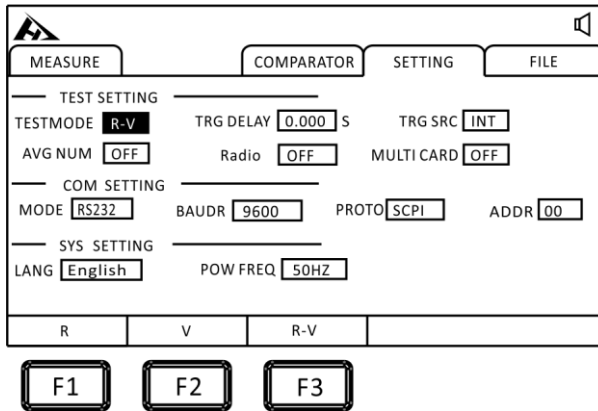

Press [F1] set R mode, test and display resistance only (as shown below); press [F2] set V mode, test and display voltage only; press [F3] select R-V mode, test and display voltage and resistance at the same time.

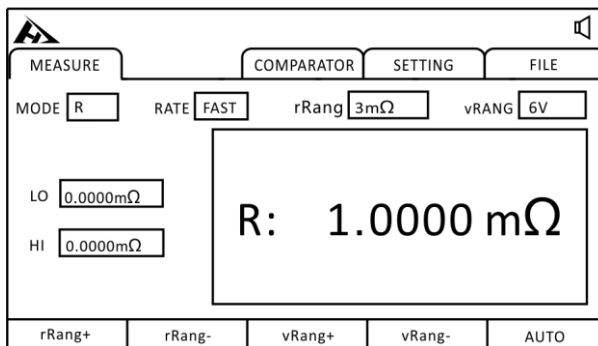

## 3.4 Trigger delay setting

Set trigger delay and adjust measurement stability time. By using this function, even if the contact of the object under test is unstable, the measurement can be started after the internal circuit is stable.

### 1. Select Parameter Settings Interface



Press the [PAGE] key to select Parameter setting page

### 2. select relevant menu items

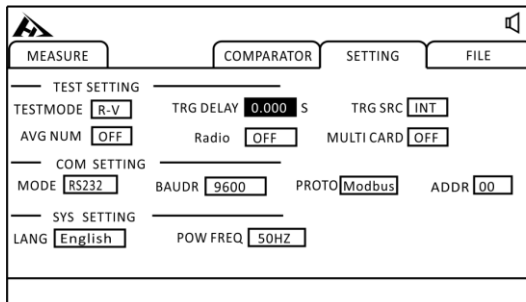

Press up,down, left and right keys to select the menu item to set

Press the [ENTER] key to enter the setting, press the upper and lower keys to set the number, if the delay time is increased, the display update of the measured value will become slower.



## 3.5 Set test trigger source

The user can select internal trigger / manual trigger / external trigger / automatic trigger.

### 1. Select Parameter Settings Interface



Press the [PAGE] key to select Parameter setting page

### 2. select relevant menu items

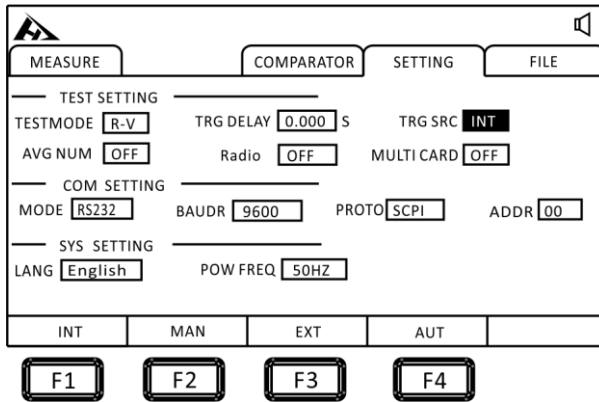

Menu Item	Meaning
[INT]	Internal trigger (instrument internal cycle trigger test)
[EXT]	External trigger (external IO port signal trigger, see Chapter 7)
[MAN]	manually triggered (press panel TRG key to trigger a test)
[AUT]	Automatic testing (automatic determination of whether tested parts are connected and tested)

## 3.6 Average number of times

Average processing and display of multiple measurements. By using this function, the beat of the measured value can be reduced and the interference can be suppressed.

**Average number of times:**

**OFF ↔ 2 ↔ 3 ↔ ... ↔ 15 ↔ 16**

### 1. Select Parameter Settings Interface



Press the [PAGE] key to select Parameter setting page

### 2. select relevant menu items

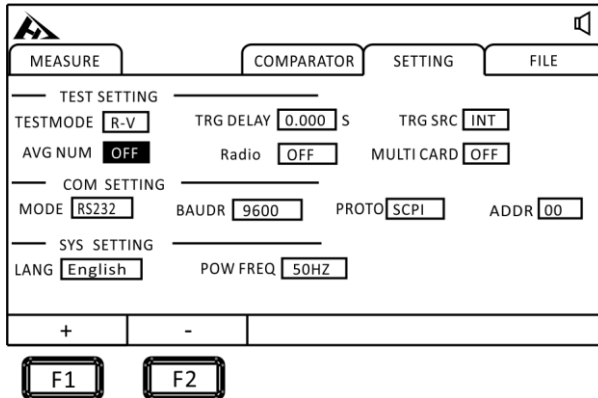

Add or subtract the average number of times by F1][F2] or turn off the average number of times.

Menu Item	Meaning
<b>[OFF]</b>	Average number function off
<b>[2]</b>	Take 2 averages to show

[3]	Take 3 averages to show
[...]	Take 4~14 averages to show
[15]	Take 15 averages and show
[16]	Take 16 averages and show

### 3.7 Broadcast Mode Settings

When broadcast mode is in ON state, test data will be automatically uploaded to the communication side in all trigger modes, and test data will not be uploaded in OFF state.

#### 1. Select Parameter Settings Interface



Press the [PAGE] key to select Parameter setting page

#### 2. select relevant menu items

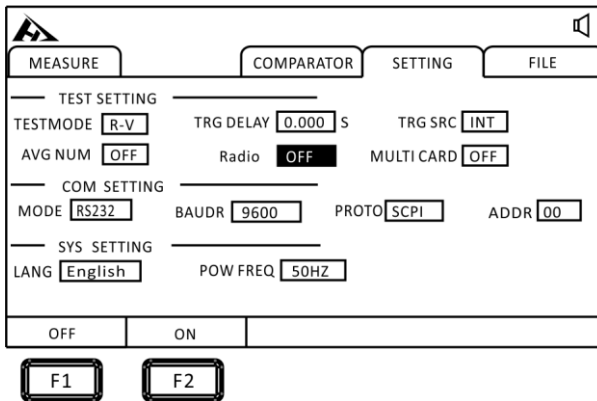

Press[F1] to turn off broadcast mode and press [F2] to turn on broadcast mode.

#### 3. Format of uploaded data

The multiplex test function is off and the data format is:

Resistance, voltage

$\pm\text{□□□.□□□E-3}$ ,  $\pm\text{□□□.□□□E-0}$

After the multiplex test is opened, the data format is:

Resistance, voltage, channel number

$\pm\text{□□□.□□□E-3}$ ,  $\pm\text{□□□.□□□E-0}$ , N

### 3.8 Multiple test settings

The multiplex test switch is mainly used to connect the multiplex scanning test equipment. When the tester needs to connect the multiplex scanner, it is turned on and closed when it is not needed. The instrument will turn on the external power supply for the scanner, and the data uploaded after the broadcast mode is turned on will automatically add the current channel number.

1. Select Parameter Settings Interface



Press the [PAGE] key to select Parameter setting page

2. select relevant menu items

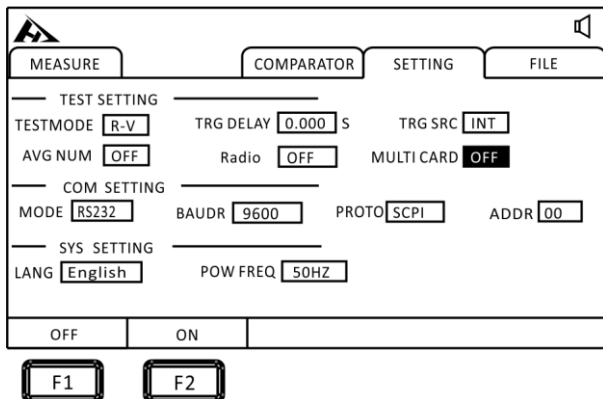

press [F1][F2] to close or open the multiplex test.

## 3.9 System settings

### 3.9.1 Language settings

The instrument provides two language options, Chinese and English. Meet the needs of international customers.

1. Select Parameter Settings Interface



Press the [PAGE] key to select Parameter setting page

2. Select the relevant menu item

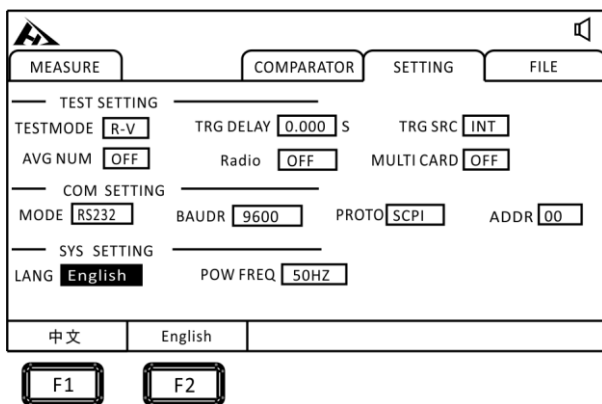

Click [F1][F2] to select the Chinese or English interface.

### 3.9.2 Power frequency settings

The power supply has 50 Hz and 60 Hz to choose. The correct setting of power frequency is helpful to resist external interference and improve the test accuracy of the instrument.

1. Select Parameter Settings Interface



Press the [PAGE] key to select Parameter setting page

## 2. select relevant menu items

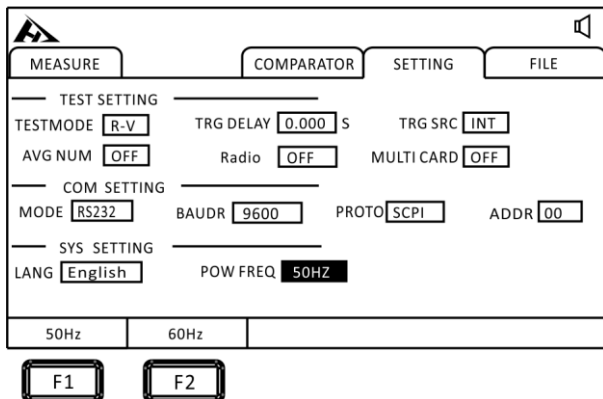

Press [F1][F2] to select a power frequency of 50 Hz or 60 Hz.

## Chapter IV Comparator Settings

The instrument has the function of comparison and sorting, and the quality of the test product can be compared and sorted according to the set value.

### 4.1 Comparator function

#### 4.1.1 Open compare mode

Press the [COMP] key to turn on or off the comparator.

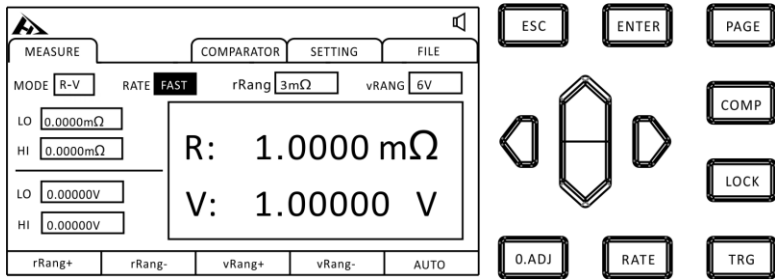

After the comparator is turned on, the current measured voltage value and resistance value will be compared with the upper and lower of the comparator, and then the sorting results will be output through the HANDLER interface.

#### 4.1.2 Comparison of Results Signal Output Mode

When the comparator function is turned on, the instrument provides three alarm outputs:

1. panel LED light alarm

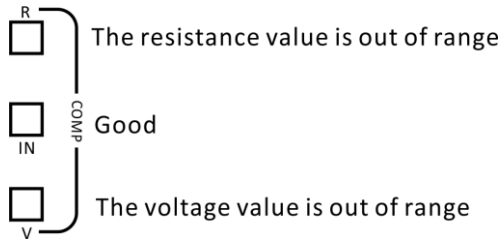

Voltage, internal resistance is not within the range, display red light V and red light R. Green light IN with both internal resistance and voltage.

2. sound alarm

See (Section 4.3).

3. External I/O port, signal output

See (section 7.1).

## 4.2 Sorting function settings

### 4.2.1 Select the comparator settings interface



Press the [PAGE] key to select COMPARATOR page

### 4.2.2 Select the relevant menu item



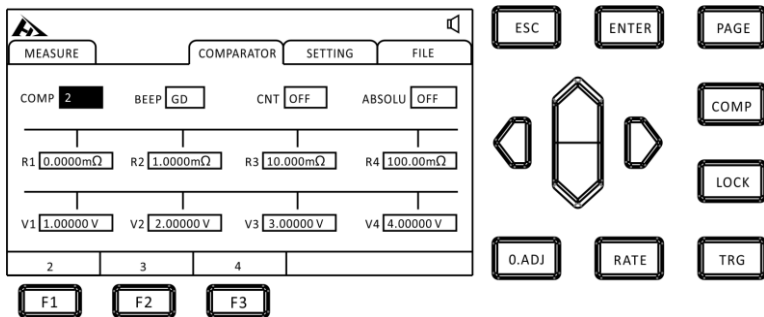

Select the sorting item and press [F1][F2][F3] to select 2/3/4 comparison mode.

### Comparative pattern :2 grades

#### 1. Separation Conditions and Results Relationship

Conditions	Results
$R1 \leq \text{Current resistance} \leq R2$	R_IN
Current resistance < R1	R_LO
Current resistance > R2	R_HI
$V1 \leq \text{Current voltage value} \leq V2$	V_IN
Current voltage value < V1	V_LO
Current voltage value > V2	V_HI

Example: select comparison function open, COMP set to 2 grades, the current comparator value set to the following:

Lower limit of resistance R1	Resistance upper limit R2
80 mΩ	120 mΩ
Lower voltage V1	Voltage ceiling V2
1.45V	1.55V

## 2. sorting results table

Battery	Internal	Voltage	Sorting results
1	100 mΩ	1.40 V	R_IN V_LO NG
2	100 mΩ	1.50 V	R_IN V_IN GD
3	100 mΩ	1.60 V	R_IN V_HI NG
4	60 mΩ	1.40 V	R_LO V_LO NG
5	60 mΩ	1.50 V	R_LO V_IN NG
6	60 mΩ	1.60V	R_LO V_HI NG
7	150 mΩ	1.40 V	R_HI V_LO NG
8	150 mΩ	1.50 V	R_HI V_IN NG
9	150 mΩ	1.60 V	R_HI V_HI NG

## Comparative pattern :3 grades

### 1. Separation Conditions and Results Relationship

Conditions	Results
$R1 \leq \text{Current resistance} < R2$	R_P1
$R2 \leq \text{Current resistance} \leq R3$	R_P2
Current resistance < R1 or Current resistance > R3	R_NG
$V1 \leq \text{Current voltage value} < V2$	V_P1
$V2 \leq \text{Current voltage value} \leq V3$	V_P2
Current voltage value < V1 or Current voltage value > V3	V_NG

Example: select comparison function open, COMP set to 3 grades, the current comparator value set to the following:

Resistance lower limit R1	Resistance upper limit R2	Resistance upper limit R3
80 mΩ	120 mΩ	160 mΩ
Lower voltage V1	Voltage upper limit V2	Voltage upper limit V3
1.40V	1.50 V	1.60 V

## 2. sorting results table

Battery	Internal	Voltage	Sorting results
1	60 mΩ	1.30 V	R_NG V_NG NG
2	90mΩ	1.45 V	R_P1 V_P1 GD
3	130mΩ	1.55 V	R_P2 V_P2 GD
4	180 mΩ	1.70 V	R_NG V_NG NG

Note: abnormal measurement is detected and no sorting signal is output.

## Comparative pattern : 4 grades

### 1. Separation Conditions and Results Relationship

Conditions	Results
$R1 \leq \text{Current resistance} < R2$	R_P1
$R2 \leq \text{Current resistance} < R3$	R_P2
$R3 \leq \text{Current resistance} \leq R4$	R_P3
Current resistance $< R1$ or Current resistance $> R4$	R_NG
$V1 \leq \text{Current voltage value} < V2$	V_P1
$V2 \leq \text{Current voltage value} < V3$	V_P2
$V3 \leq \text{Current voltage value} \leq V4$	V_P3
Current voltage value $< V1$ or Current voltage value $> V4$	V_NG

Example: select comparison function open, COMP set to 4 grades sorting, the current comparator value set to the following.

Resistance lower limit R1	Resistance upper limit R2	Resistance upper limit R3	Resistance upper limit R4
80 mΩ	100 mΩ	120 mΩ	140 mΩ
Lower voltage V1	Voltage upper limit V2	Voltage upper limit V3	Voltage upper limit V4
1.40V	1.50 V	1.60 V	1.70 V

## 2. sorting results table

Battery	Internal	Voltage	Sorting results
1	60 mΩ	1.30 V	R_NG V_NG NG
2	90mΩ	1.45 V	R_P1 V_P1 GD
3	110mΩ	1.55 V	R_P2 V_P2 GD
4	130mΩ	1.65 V	R_P3 V_P3 GD
5	150mΩ	1.75V	R_NG V_NG NG

**Note:**

Abnormal measurement detected, no sorting signal output

## 4.3 Response mode settings

After the instrument comparator opens or selects the output test result, the instrument response mode can be selected.

**Sound mode:**

OFF ↔ Qualified ↔ Unqualified

## 1. Select Comparator Settings Interface



Press the [PAGE] key to select COMPARATOR page

## 2. select relevant menu items

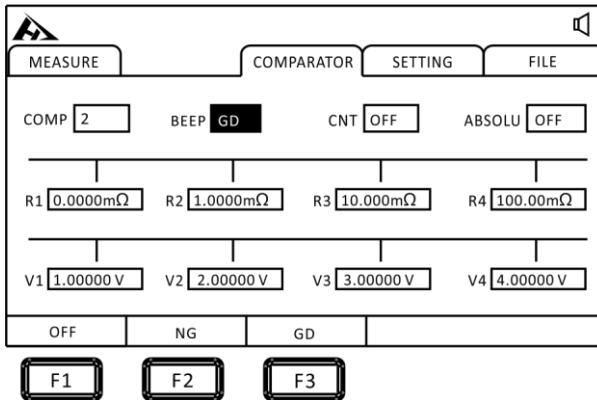

Menu Item	Meaning
[OFF]	Sorting signal closed
[NG]	Sound when unqualified
[GD]	Sound when qualified

## 4.4 Count settings

When the instrument comparator is turned on, the count is set to ON, when the machine counts the range of the test results.

### 1. Select Comparator Settings Interface



Press the [PAGE] key to select COMPARATOR page

## 2. select relevant menu items

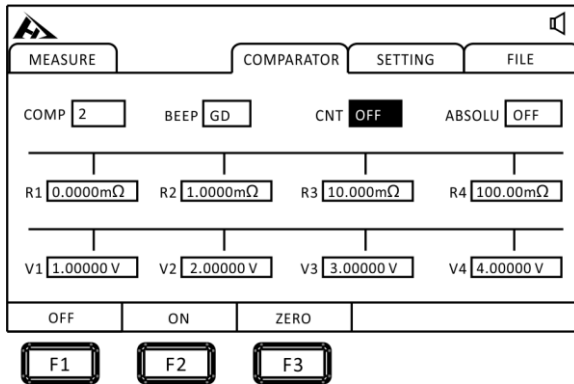

Press [F1][F2] to turn off and turn on the sorting count function, press [F3] to clear the count value.

## 4.5 Absolute set

The tester provides the function of absolute value, compares and selects the test results after absolute value operation.

### 1. Select Comparator Settings Interface



Press the [PAGE] key to select COMPARATOR page

### 2. select relevant menu items

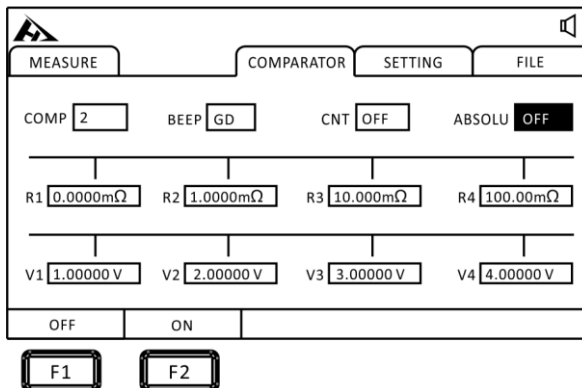

Press [F1][F2] to turn off and turn on the absolute value function.

# Chapter V Measurement

This chapter describes the functions used for correct measurement in stages, including startup settings, range scope, protection function startup.

## 5.1 Start-up test

1. Set the relevant parameters.
2. Connect the test line correctly.
3. Test started.

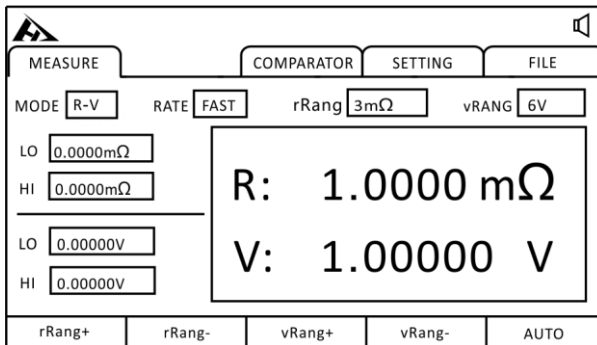

Trigger mode	Meaning
<b>Internal trigger (INT)</b>	Automatic trigger test inside instrument
<b>External trigger (EXT)</b>	Trigger test by external EXT IO TRG signal
<b>Manual trigger (MAN)</b>	Manually press the [TRG]、RS232、LAN port instruction to trigger the test
<b>Automatic trigger (AUT)</b>	Automatically judge the parts to be tested and test them

**Note:**

- You can not restart another test before the test is over.
- When the EOC signal of the EX.I/O port is LOW, the test can not be triggered.

## 5.2 Measured value display

The following is the test range, and if the following range is exceeded, display (-----), test current and range:

### Impedance measurement

Resistance Range	Measuring current	Maximum display value	Resolution ( $\Omega$ )
300m $\Omega$	10mA	320.00m $\Omega$	10 $\mu\Omega$
3 $\Omega$	1mA	3.2000 $\Omega$	100 $\mu\Omega$

### Voltage measurement

Range	Maximum display value	Resolution
20V	$\pm 20.0000V$	100 $\mu V$

## 5.3 Zeroing

Please zero in the following cases. (Resistors below 3% $\pm$  f.s. can be removed for each range)

- ◇ Residual display due to electromotive force, etc
- ◇ Replacement of 4 terminal test lines
- ◇ Abnormal test value
- ◇ Changes in ambient temperature and humidity



**Note:**

- ◇ After zeroing, if the ambient temperature changes or the test line changes, zero again.
- ◇ Please zero in all ranges used. When manual range, zero is adjusted only under the current range; when automatic range, zero is adjusted for all ranges.
- ◇ If a resistance is measured smaller than the resistance value at zero, the measured value is negative.

Example: connect 1 mΩ resistance under 300 mΩ range and zero.  
After zeroing, if short circuit, show -1 mΩ.

**Implementation of zero**

1. short circuit test line

9363- A test clamp test line

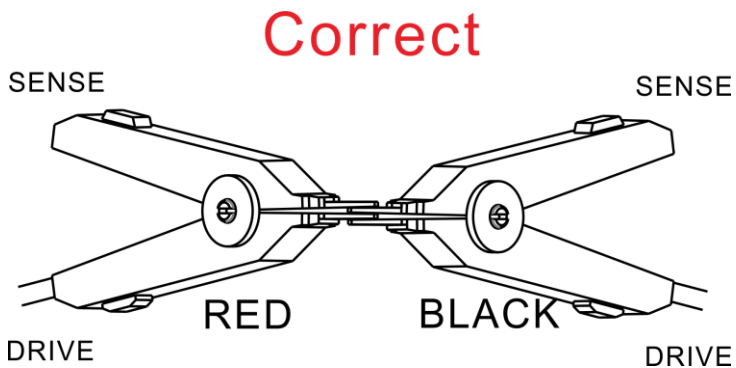

# Error

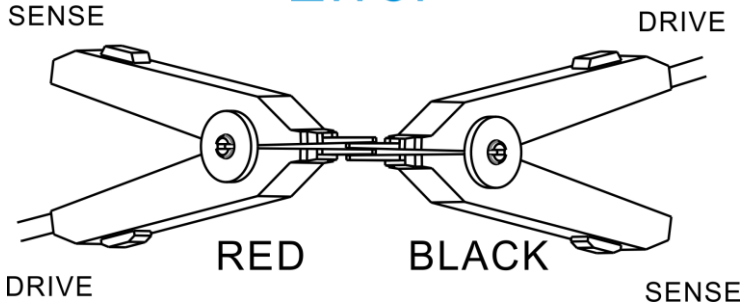

9363- B probe test line

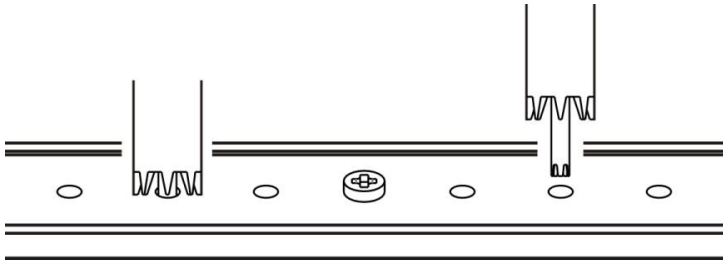

2. confirm measurement within  $\pm 50\%$  f.s of value.

When the measured value is not shown, please confirm that the wiring of the test line is correct.

The following picture shows the correct connection:

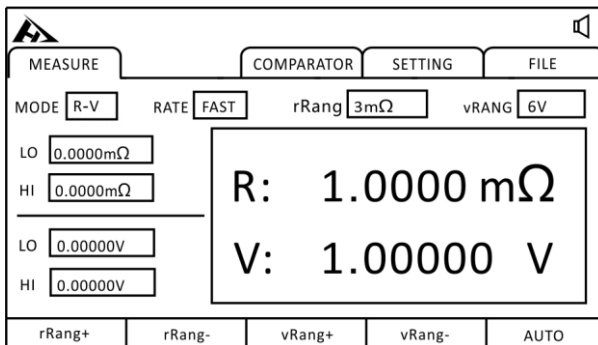

The following picture shows the wrong connection:

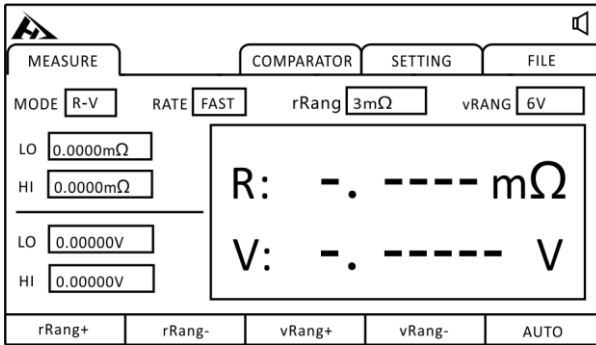

### 3. Zeroing

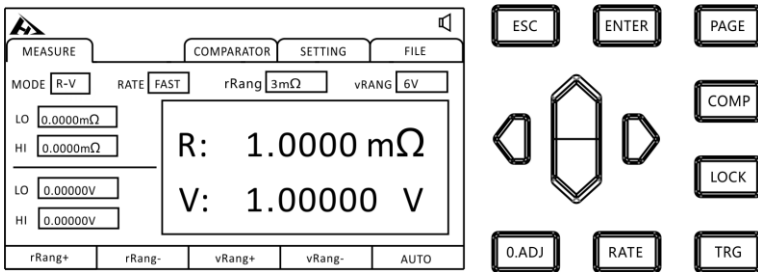

After clamping the test clip or press the pen, Click [0.ADJ], Prompt zeroing will be executed, Press the [ENTER] key to zero, Press the [ESC] key to stop clearing.

### 4. zero after implementation

Zero setting success, will display zero success icon in the middle of the display measurement screen, and then return to the measurement interface. Zero setting failure, display zero clearance failure icon, return to the measurement interface.

### Zero failure

If zero can not be adjusted, it may be that the measured value before zero adjustment exceeds the  $3\% \pm$  full range of each range, or is in an abnormal state of test. Please do the correct wiring again and reset the zero. When the resistance value of self-made cable is high, please reduce the wiring resistance because it can not be adjusted to zero.

**Note:**

When the zero adjustment fails, the zero adjustment of the current range is lifted.

## Chapter VI Preservation of Measurement Panel

All measurement conditions can be saved, retrieved, or deleted as files.



Press the [PAGE] key to select FILE page

After entering the interface, press the upper and lower keys, you can view the data save records, you can save, load, clear the current records and other operations.

### 6.1 Save Panel Settings

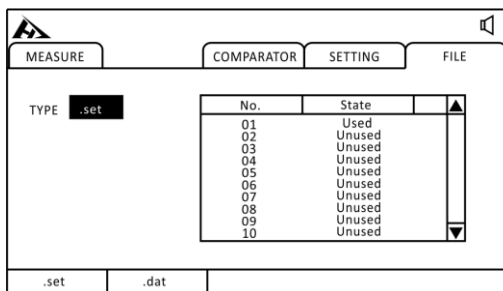

Press up, down, left and right keys to select the menu item to set

Browse the current settings with the upper and lower keys and press [F1] to save the current settings. A total of 30 sets of test settings can be saved. Convenient for different products to quickly switch settings.

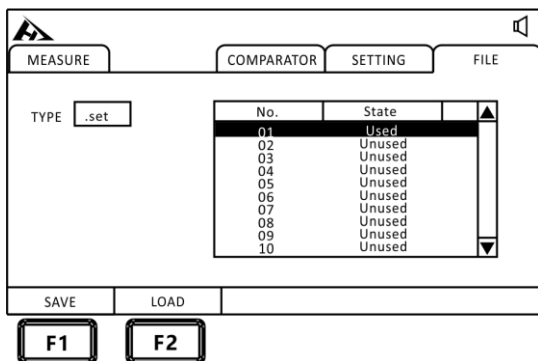

Press [F1] to save the parameters to the selected file.

## 6.2 Call measurement settings

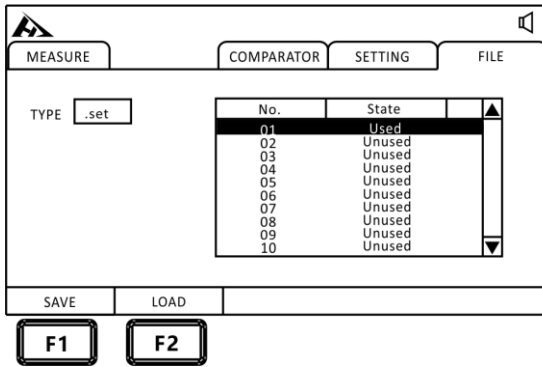

Press [F2] to load the saved parameters

Browse the current settings with the upper and lower keys and press the F2 load key to adjust the current settings.

## 6.3 Save measurement data settings

If you open the save data in trigger mode other than INT mode, the test data will be saved to the machine in order, a total of 15 files can be saved, each file can save 400 sets of test data.

1. Select File Settings Interface



Press the [PAGE] key to select FILE page

2. select relevant menu items

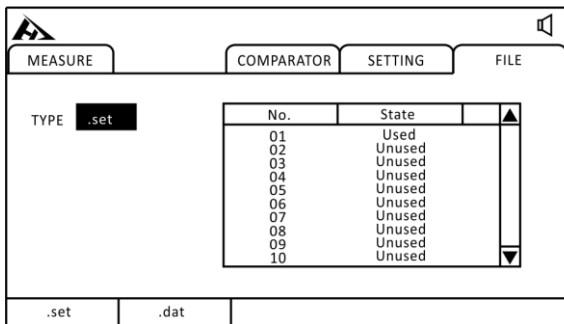

**F2**

Press [F2] to  
File save page

### 3. Open Data Save Function

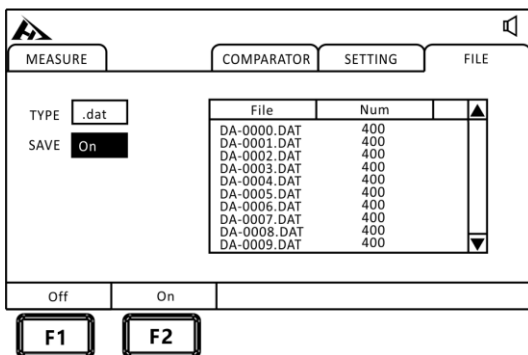

**F2**

Press [F2] to start  
saving data except  
for INT trigger mode

## 6.4 Save Measurement Data Export

Insert the U disk to export the data group you need to view to the U disk. And on the computer with parsing software exported to the format you need.

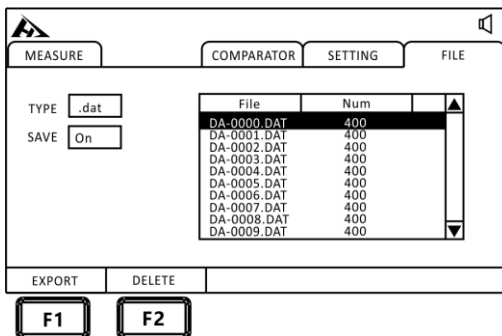

**F1**

**F2**

Press [F1] to export the  
selected data to the U disk.  
Press the [F2] key to delete  
the selected data.

## CHAPTER VII EXT I/O Interface (Handler)

The EXT I/O terminals on the rear panel of the instrument support external control, provide the output of the test and comparison judgment signal, and accept the input TRG signal. All signals use an optical coupler. Through the instrument panel setting, understanding the internal circuit structure and paying attention to safety matters is conducive to better connection control system.

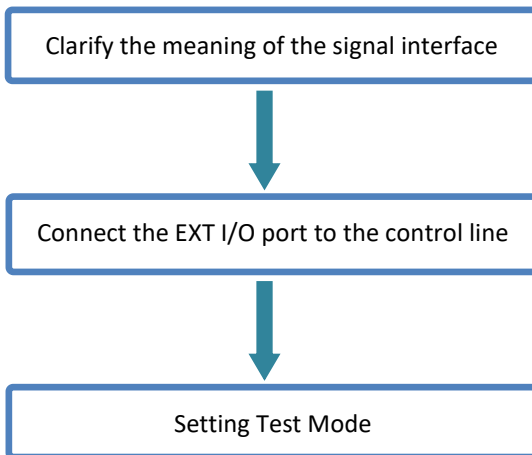

### 7.1 EXT I/O ports and signals

During this section, you will learn about the connection and introduction of the EXT I/O.



Do not plug EXT I/O ports during testing  
Do not connect IO port to test end



## Input schematic diagram

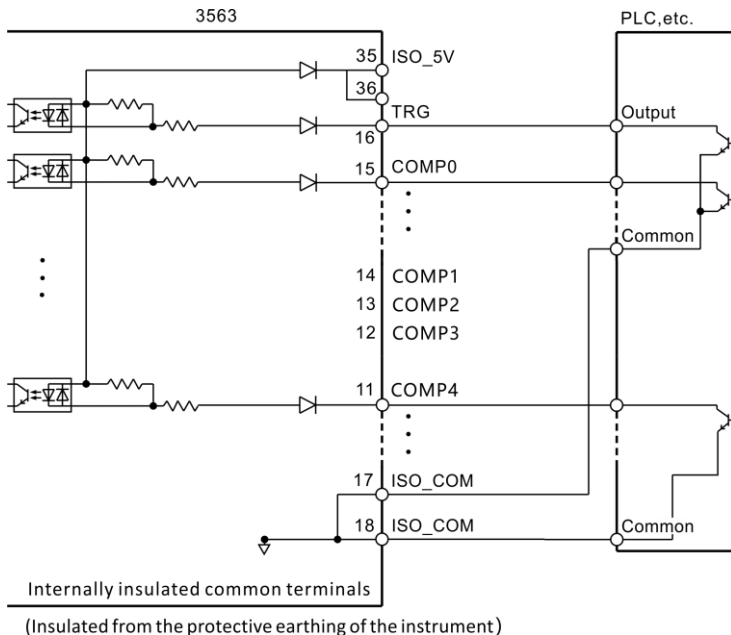

## Output schematic diagram

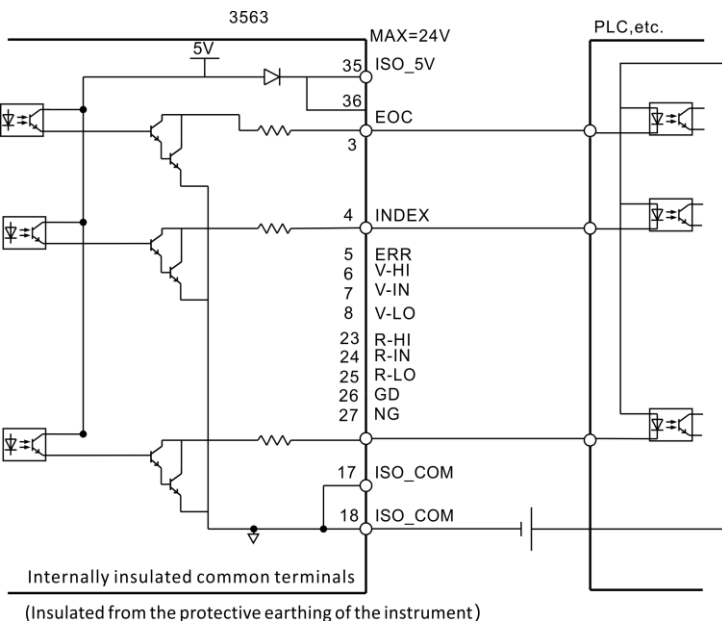

## 7.1.1 Port signal details

### Port and signal description

The EXT I/O port connector adopts the D-SUB bus terminal of 36-PIN foot.

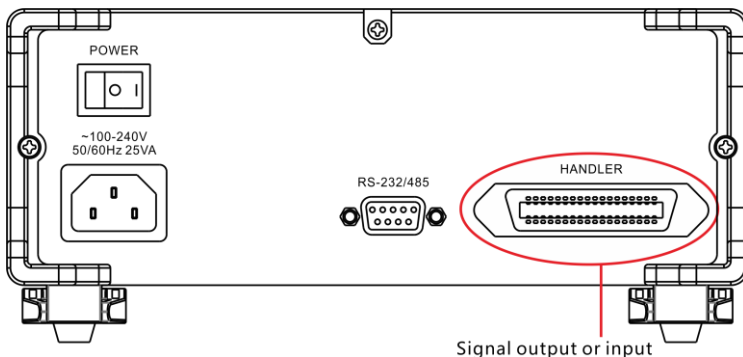

### Port Details

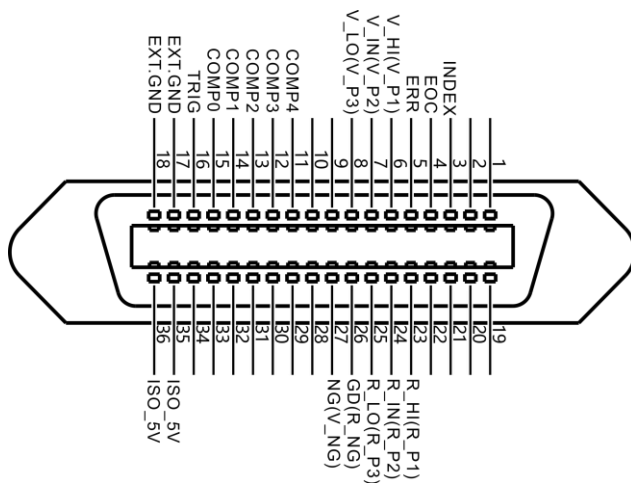

(Instrument end)

Power supply terminal

Serial number	Terminal name	Meaning
17	EXT.GND	isolated signal ground (user power ground)
18		
35	ISO_5V	Isolation 5 V Power output
36		

#### Comparison of output signals

3	INDEX	Sampling End Signal
4	EOC	Test completion signal (busy signal)
5	ERR	Abnormal measurement error output
26	GD(R_NG)	Pass output of two-stage sorting comparator Unqualified output of third and fourth grade sorting resistors
27	NG(V_NG)	Unqualified output of two-stage sorting comparator 3rd and 4th file sorting compare voltage unqualified output
6	V_HI(V_P1)	Super-output of two-stage sorting comparison voltage(Unqualified) Grade 3 and Grade 4 Separation and Comparison Voltage First Class Output
7	V_IN(V_P2)	two-stage sorting compare voltage qualified output 3rd and 4th grade sorting compare voltage second class output
8	V_LO(V_P3)	Over-output of two-stage sorting comparison voltage(Unqualified) 3rd and 4th grade sorting compare voltage 3rd grade output

23	R_HI(R_P1)	Super-output of the second-grade sorting resistance(Unqualified) 3rd and 4th grade sorting resistance first class output
24	R_IN(R_P2)	Second Class Sorting Comparative Resistance Qualified Output 3rd and 4th grade sorting comparative resistance second class output
25	R_LO(R_P3)	Super output of second-grade sorting and comparison resistance (Unqualified) 3rd and 4th grade compare resistance 3rd grade output

#### External control signal input

15	Comp 0	Comparator record selector. Optional file 1~30.
14	Comp 1	
13	Comp 2	
12	Comp 3	
11	Comp 4	
16	Trig	Test Trigger.

#### Comparator Record Selection Table

COMP 4-0	Record number	COMP 4-0	Record number	COMP 4-0	Record number	COMP 4-0	Record number
11111	No change	10111	8	01111	16	00111	24
11110	1	10110	9	01110	17	00110	25
11101	2	10101	10	01101	18	00101	26
11100	3	10100	11	01100	19	00100	27
11011	4	10011	12	01011	20	00011	28
11010	5	10010	13	01010	21	00010	29

11001	6	10001	14	01001	22	00001	30
11000	7	10000	15	01000	23	00000	No change

Note: in order to avoid damaging the interface, do not exceed the power supply requirements.



In order to avoid damage to the interface, please connect after the instrument is closed.

If the output signal user is used to control the relay, the relay must use a reverse energy release diode.

## 7.1.2 Port Signal Connection Mode

### Electrical performance parameters

Isolation power output: 4.8~5.3 VDC

100 mA. maximum output current

Output signal:

the optocoupler isolation band drives the chip.

Maximum load voltage 30 V.

Maximum output current :50 mA.

Input signal:

Photoelectric isolation.

Low level valid.

Maximum current :50 mA.

### Input circuit connection

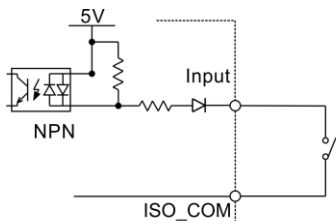

Switched input

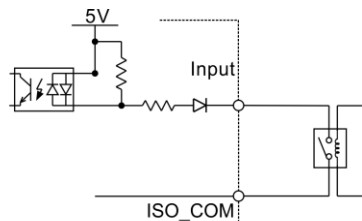

Relay input

## Output circuit connection

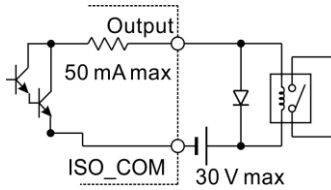

Driving relay

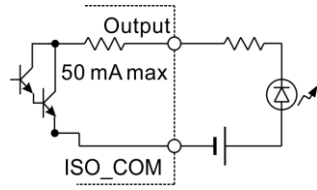

Driving LED Light

## 7.2 Sequence diagram

Each signal level represents the ON/OFF state of the contact, and the upper horizontal bar represents the low level effective.

### 7.2.1 Sequence diagram of external trigger

External trigger [EXT] set (I/O output mode to hold)

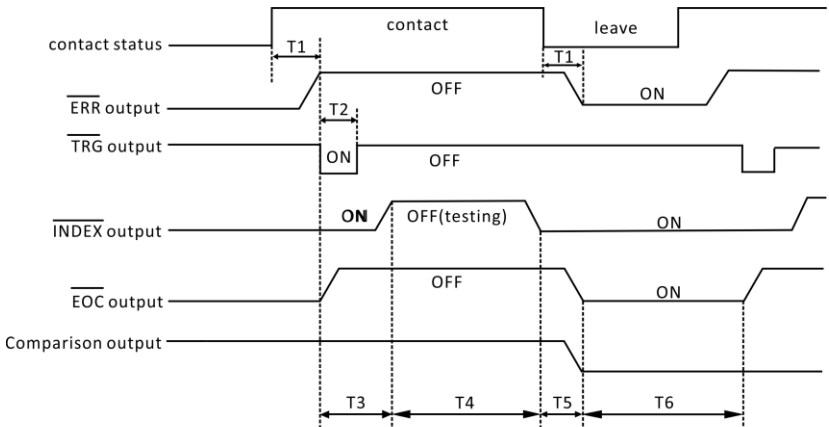

T1: 1.5ms ERR output response time      T2: Minimum 0.5ms descent edge trigger

T3: Delay time

T4: Minimum 8.6ms(measurement time)

T5: 0.5ms operation time

T6: Hold until the next trigger

Note: ERR (low) test exception, ERR (low) test is normal.

	Project	Time
T1	ERR output response time	1.5mS <sub>MAX</sub>
T2	TRG, Signal pulse width	5mS <sub>MIN</sub>
T3	Time delay	5mS <sub>MAX</sub> + Measurement delay
T4	ADC sampling time (R-V mode)	Super fast      8.6ms
		Fast              18ms
		Medium speed   44ms
		Slow speed      288ms
T5	Data processing display time	1mS <sub>MAX</sub>

### 7.2.2 Read flow when triggered externally

The following is the process from the start of the measurement to the acquisition of the measured value when using an external trigger.

After the instrument determines the result (HI、IN、LOW、ER、GD、NG) , the EOC signal is output immediately. When the response of the controller input circuit is slow, the waiting time is needed from the ON of the detection EOC signal to the reading judgment result.

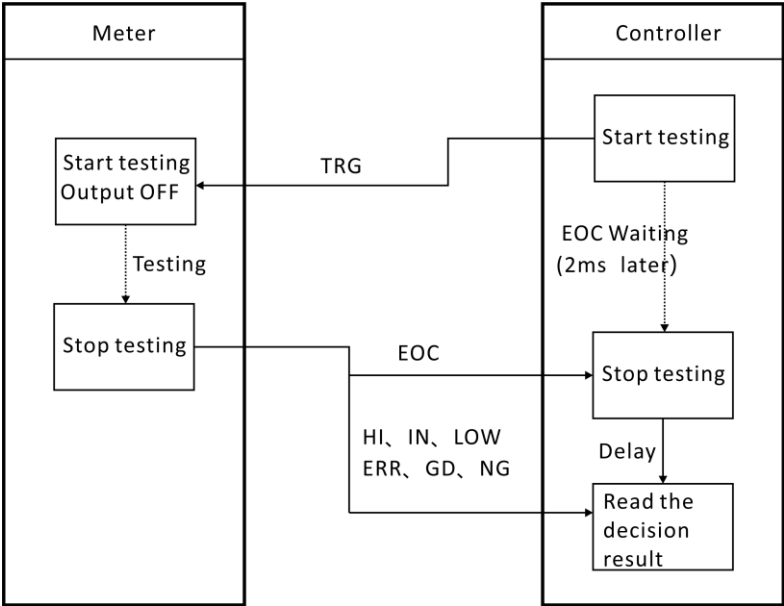



## CHAPTER VIII Communications

The instrument provides three communication modes, RS232C, RS485 、 LAN (Ethernet protocol adopts TCP protocol) communication mode. Instruments provide two communication protocols, SCPI、 MODBUS. Communication instructions refer to the instruction set in the CD.



It is forbidden to connect the communication port to the test port, otherwise the instrument will be damaged.

### 8.1 RS232 Communication Mode

RS232 communication mode adopts 3 line communication mode.

#### 8.1.1 Interface and Cable

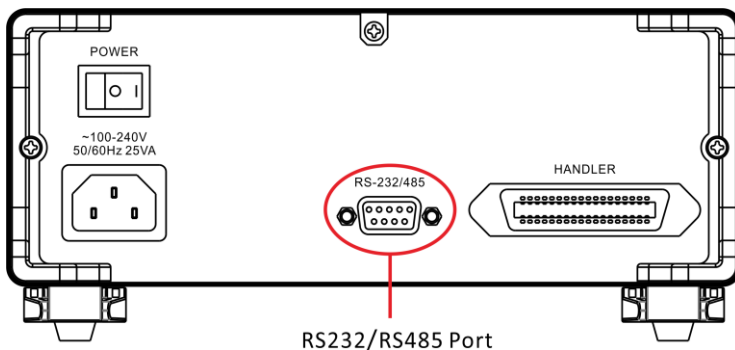

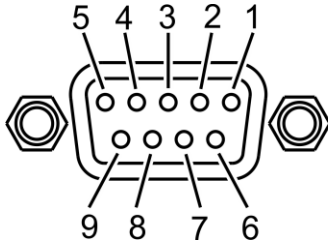

9-pin D-Sub Female

### 8.1.2 RS232 Connection Mode

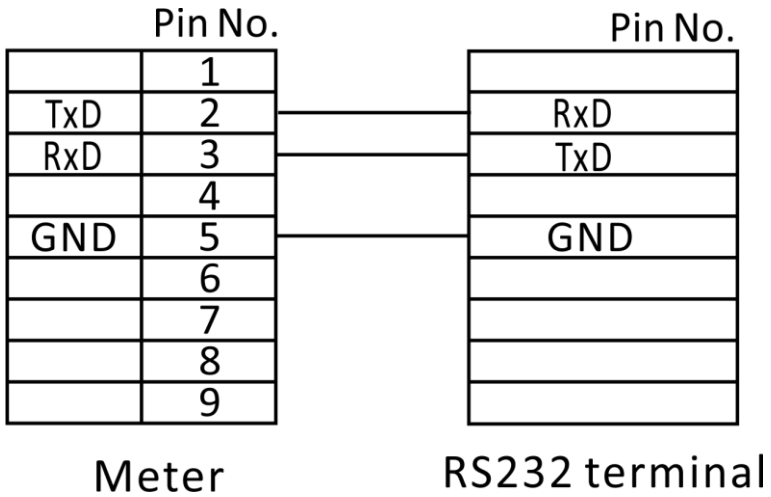

### 8.1.3 RS232 Communications Settings

1. select the newsletter page



Press the [PAGE] key to select the Parameter Settings page

2. choose RS232 communication mode

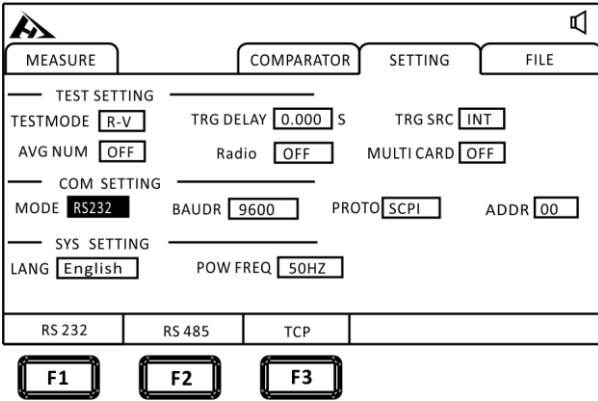

3. choose the baud rate

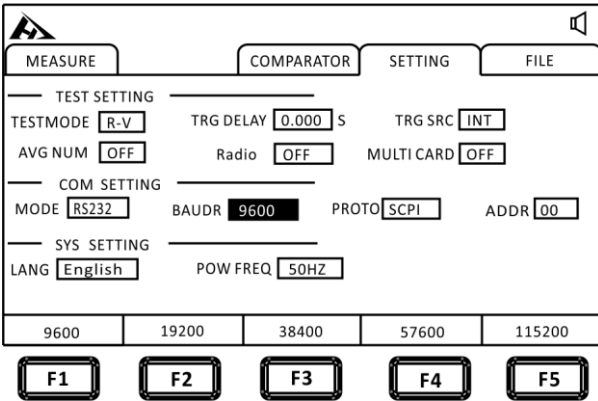

4. Select Communication Protocol

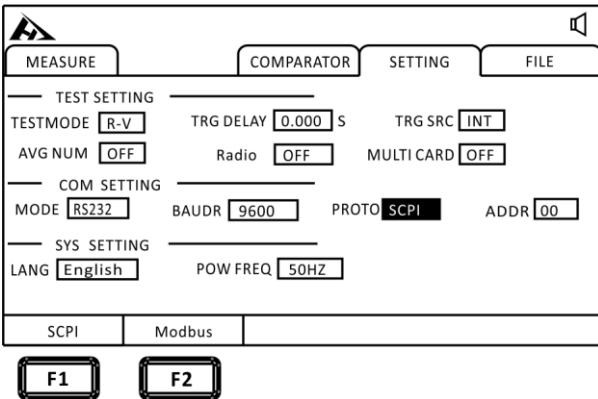

## 8.2 RS485 Communication Mode

### 8.2.1 RS485 Connection Mode

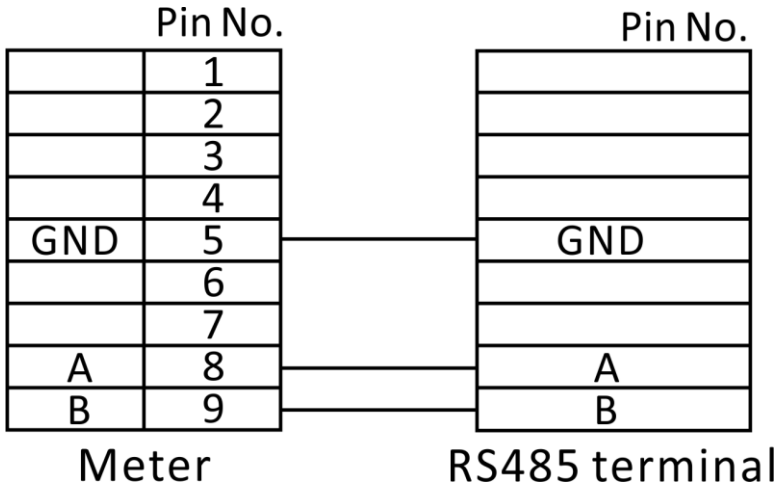

### 8.2.2 RS485 Communications Settings

1. Select the newsletter page



Press the [PAGE] key to select the Parameter Settings page

2. Choose RS485 communication mode

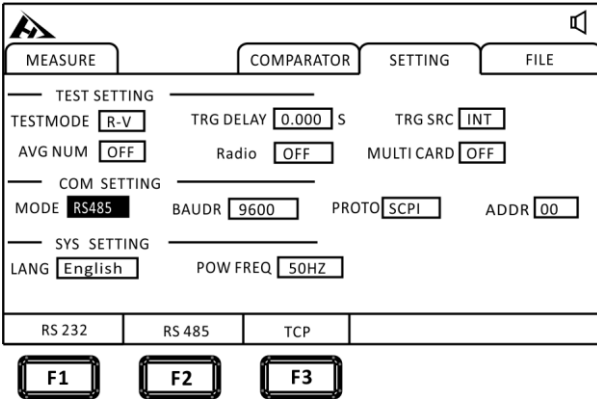

### 3. Choose the baud rate

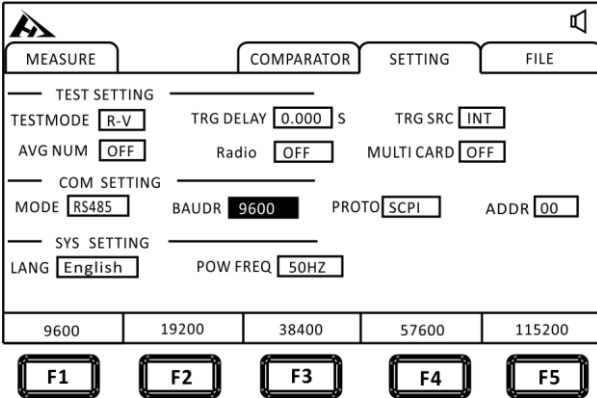

### 4. Address setting

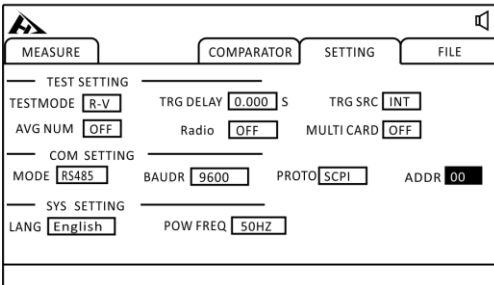

Press [ENTER] to ENTER the Settings and use the up, down, left, and right keys to set the desired address

## 8.3 USB interface

The front panel of the instrument has a USB interface, which is used as a HOST function, inserted into the U disk for upgrading programs and saving data or settings.

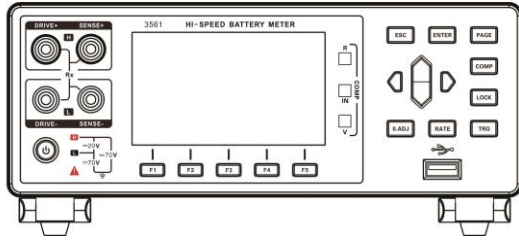
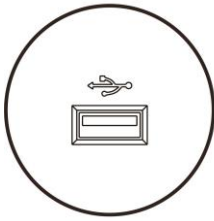

# Chapter IX Parameters

## 9.1 General parameters

General functions:

<b>Measurement function</b>	Voltage, AC resistance test
<b>Scope of testing</b>	Resistors 0.01m $\Omega$ to 3 $\Omega$ , voltage 0 V to 20 V
<b>Test speed (MAX)</b>	Super fast 66 times per second, fast 30 times per second, Medium speed 10/ s, slow 3/ s.
<b>Automatic trigger</b>	
<b>Maximum output current</b>	100mA
<b>Range Overlimit Display</b>	Super range "-----"
<b>Input terminals</b>	Banana plug
<b>Operating key</b>	Rubber bond
<b>Display</b>	3.5 inches TFT
<b>Precision Guarantee Period</b>	1 year
<b>Operating temperature and humidity</b>	0°C to 40°C 80% RH below (no condensation)
<b>Storage temperature and humidity</b>	-10°C to 60°C 80% RH below (no condensation)
<b>Operating environment</b>	Indoor, highest altitude m 2000
<b>Power supply</b>	Voltage :100 V ~240 V AC Frequency :50 Hz/60Hz
<b>Power</b>	10 W

<b>consumption</b>	
<b>Size</b>	About 325 mm x 215 mm x 96 mm
<b>Weight</b>	About 2kg

## 9.2 Accuracy

Test conditions for the following indicators:

Temperature:  $20 \pm 3^\circ\text{C}$

Humidity:  $< 80\% \text{RH}$

Preheating more than 15 minutes

Calibration within 1 year

Accuracy :  $\pm(\text{reading accuracy} + \text{range accuracy})$

### Resistance measurement accuracy:

	Range	Maximum reading	Accuracy (slow)	Resolution	Test current
1	300m $\Omega$	320.00m $\Omega$	0.5%+0.02%FS	0.01m $\Omega$	10mA
2	3 $\Omega$	3.2000 $\Omega$	0.5%+0.02%FS	100 $\mu\Omega$	1mA

1: measuring current error  $\pm$  less than 10%.

2: superfast plus 0.03%FS, fast plus 0.03%FS, medium speed plus 0.01% FS.

### Voltage measurement accuracy:

	Range	Maximum reading	Testing accuracy	Resolution
1	20V	$\pm 20.0000\text{V}$	0.01%+0.002%FS	100 $\mu\text{V}$

1. Add 0.003%FS for ultra-fast ,0.002%FS for fast ,0.001%FS for medium speed.



# CHAPTER X SCPI Communication Instructions

## 10.1 General instructions

Instrument commands are divided into two types: public commands and SCPI( programmable instrument standard commands) commands. Common commands are defined by IEEE488.2-1987 standards and apply to all instrument devices, but this instrument does not support all common commands. SCPI command is tree-like.

### 1.\* IDN? Instruction

Function: Query version number

Examples:

Delivery :\* IDN?:

Return: Hopetech,3561,V1.0

### 2.\* TRG

Function: Bus trigger command available when set to bus trigger

Return: resistance value, voltage value (multiplex function off)

Resistance value, voltage value, channel number (multiplex function on)

Example: See FETCH Instruction

### 3.TRG

Function: bus trigger command, if not bus trigger automatically changed to bus trigger.

Return: resistance value, voltage value (multiplex function off)

Resistance value, voltage value, channel number (multiplex function on)

Example: See FETCH Instruction

## 10.2 SCPI Instruction Structure

The instruction of tree structure is root command (root command), or root (root). If you want to reach the lower level instruction, you must follow a specific path to reach.

Command Terminator: an end character entered by a command, such as a NL (Newline character, ASCII code 10).

Colon (:): colon is the level of the command, indicating the next level of the command.

semicolon (;): a semicolon indicates the beginning of multiple commands.

Question mark (?): A question mark indicates a query.

Comma (,): Comma is a separator of multiple parameters.

spaces ( ): spaces are delimiters of commands and parameters.

The following figure shows how to reach lower levels of instruction by using colons, semicolons.

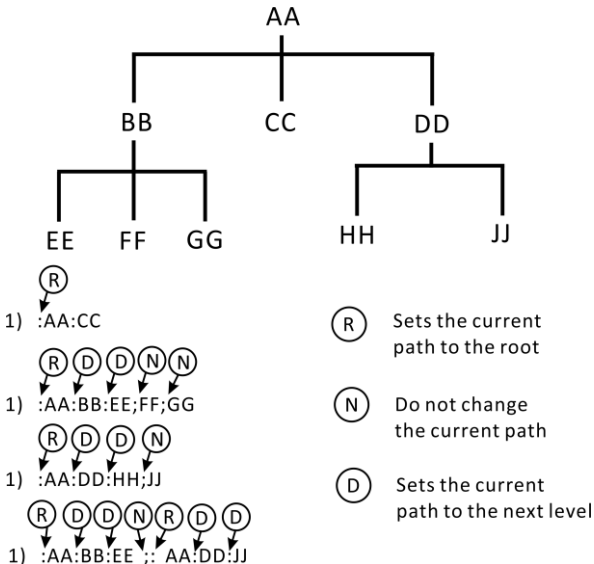

SCPI Instruction Tree Structure

## 10.3 SCPI sub-instruction system

1.: FUNction {RV|RES|VOLT}

Function: Set or query test mode

Return: RV,RES,VOLT

Note: RV voltage resistance test function

RES Resistance Test Function

VOLT voltage test function

Example: Set Test Mode

Sending: :FUNction RV:

Example: Query Test Mode

Sending: FUNction?:

Return: RV

2.: RESistance: RANGe {<numeric\_value>}

Function: Set or query resistance range

Returns: numeric, range 0-1

Example: the current range is set to 1 range

Sending: RESistance:RANGe 1

Example: Ask about the current range

Sending: RESistance:RANGe?

Return :1

3. :VOLTage:RANGe {0}

Function: Set or query voltage range

Return :0

Example: the current range is set to 0 range

Sending: VOLTage:RANGe 0

Example: Ask about the current range

Sending: VOLTage:RANGe?

Return :0

4. :AUTorange {0|1|OFF|ON}

Function: Automatic setting or query range

Return :0 off ,1 on

Example: automatic range setting

Sending: :AUTorange OFF

Return :0 off ,1 on

Example: Ask about the current range automatically

Sending: :AUTorange?

Return :0

5. :SAMPle:RATE {EX|FAST|MEDIum|SLOW}

Function: Set or query sampling rate

Return: FAST fast, MED medium speed, SLOW slow

Example: Setting Sampling Rate

Sending: :SAMPle:RATE OFF

Return :0 off ,1 on

Example: Query Sampling Rate

Sending: :SAMPle:RATE?

Return: SLOW

6. :CALCulate:AVERage:STATe{0|1|OFF|ON}

Function: Set or query if average function is on

Return :0 off ,1 on

Example: Ask if the average function is turned on

Sending: : :CALCulate:AVERage:STATe?

Return :0

7. :CALCulate:AVERage {<numeric\_value>}

Function: Set or query average number of times

Return :2-16

Example: Average number of queries

Sending: :CALCulate:AVERage?

Return :2

Example: Set the average number of times

Sending: :CALCulate:AVERage 5

7 :CALCulate:LIMit:STATe {0|1|OFF|ON}

Function: Sets or queries whether the comparator is on

Return :0 off ,1 on

Example: Query whether the comparator is on

Sending: :CALCulate:LIMit:STATe?

Return :0

Example: Set comparator on

Sending: :CALCulate:LIMit:STATe ON

9. :CALCulate:LIMit:BIN {2|3|4}

Function: Set or Query Comparator number of sorting files

Return :2 Upper and lower sorting ,3 Three-step sorting ,4

Four-step sorting

Example: Query the number of comparators

Sending: :CALCulate:LIMit:BIN?

Return :2

Example: Set the number of comparators

Sending: :CALCulate:LIMit:BIN 2

10. :CALCulate:LIMit:BEEPer {OFF|HL|IN}

Function: Sets or queries the comparator's output

Return: OFF noise off, HL unqualified sound, IN qualified sound

Example: Query comparator output

Sending: :CALCulate:LIMit:BEEPer?

Return: OFF

Example: Set the comparator's output

Sending: :CALCulate:LIMit:BEEPer HL

11. :CALCulate:LIMit:RESistance {1|2|3|4},{<numeric\_value>}

Function: Set or query comparator resistance upper limit value

Return: <numeric\_value>

Example: Set comparator resistance upper limit value 1

Sending: :CALCulate:LIMit:RESistance:UPPer 1,1e1

Example: Query comparator resistance upper limit value 1

Sending: CALCulate:LIMit:RESistance:UPPer? 1

Return : 1.0000e1

12.:CALCulate:LIMit:RESistance:LOWer

{1|2|3|4},{<numeric\_value>}

Function: Set or query the lower limit of comparator resistance

Return: <numeric\_value>

EXAMPLE: Setting comparator resistance lower limit 1

Sending: :CALCulate:LIMit:RESistance:LOWer 1,1e-1

EXAMPLE: Query comparator resistance lower limit 1

Sending: :CALCulate:LIMit:RESistance: LOWer? 1

Return : 1.0000e-1

13. :CALCulate:LIMit:VOLTage:UPPer {1|2|3|4},{<numeric\_value>}

Function: Set or query comparator voltage upper limit values

Return: <numeric\_value>

Example: Set comparator voltage upper limit value 1

Sending: :CALCulate:LIMit:VOLTage:UPPer 1,10

Example: Query comparator voltage upper limit 1

Sending: :CALCulate:LIMit:VOLTage:UPPer? 1

Return : 10.0000

14.:CALCulate:LIMit:VOLTage: LOWER {1|2|3|4},{<numeric\_value>}

Function: Set or query comparator voltage lower limit values

Return: <numeric\_value>

Example: Set comparator voltage lower limit value 1

Sending: :CALCulate:LIMit:VOLTage:LOWER 1,1

Example: Query comparator voltage lower limit 1

Sending: :CALCulate:LIMit:VOLTage:LOWER? 1

Return : 1.00000

15:SYSTem:LFRequence

Function: Set or query power frequency

Return :50,60

Example: Query Power Frequency

Sending: :SYSTem:LFRequence?

Return :50

Example: set power frequency

Sending: :SYSTem:LFRequence 50

#### 16 :SYSTem:SAVE

Functions: save current test mode, test speed, test range, trigger delay, comparator setting information

#### 17 :SYSTem:LOAD

Functions: load saved test mode, test speed, test range, trigger delay, comparator setting information

#### 18 :TRIGger:SOURce

Function: Set or query trigger source

Return: INT,MAN,EXT,AUT

Example: Set Trigger Source

Sending: :TRIGger:SOURce INT

Example: Query Trigger Source

Sending: :TRIGger:SOURce?

Return: INT

#### 19 :TRIG:DELay

Function: Set or query trigger delay

Return: 0 to 9.999

Example: Set Trigger Delay

Sending: :TRIG:DELay 1

Example: Query Trigger Delay

Sending: :TRIG:DELay?

Return :1

#### 20 :FETCh?

Function: Return test results

When the multiplex is off, returns the format:

$\Omega$ V mode return<Resistance value>,<Voltage value>

$\Omega$  mode return <Resistance value>,<

V mode return <Voltage value>



When the multiplex is turned on, return the format:

$\Omega$ V mode return<Resistance value>,<Voltage value>,<N>

$\Omega$  mode return <Resistance value>,<N>

V mode return <Voltage value>,<N>

#### Measuring Resistance Data Format

No.	Range	Normal test value	Super range	Measurement failure
1	300m $\Omega$	$\pm\text{□□□□.□□E-3}$	$\pm 1000.00\text{E}+6$	$\pm 1000.00\text{E}+7$
2	3 $\Omega$	$\pm\text{□□.□□□□E+0}$	$\pm 10.0000\text{E}+8$	$\pm 10.0000\text{E}+9$

#### Measuring Voltage Data Format

No.	Range	Normal test value	Super range	Measurement failure
1	20V	$\pm\text{□□.□□□□E+0}$	$\pm 10.0000\text{E}+8$	$\pm 10.0000\text{E}+9$

#### Channel Number Data Format

0~99

## Chapter XI MODBUS Communications Directive

The communication protocol adopts MODBUS format and RTU mode. That is ,3.5 stop bits as start and end bits. The time between each byte data does not exceed 1.5 stop bits. Select serial port type (Rs232/Rs485) and set the communication baud rate of the instrument to be consistent with the upper computer. Serial communication format: data bit 8 bits, stop bit 1 bit, no hardware handshake.

### 11.1 Register Overview

#### 11.1.1 Hold register

Name	Address	Value
Test function	0x0001	R:0x0000,V:0x0001, RV:0x0002
Resistance Range	0x0002	0x0000-0x0006
Voltage Range	0x0003	0x0000-0x0002
Automatic Range	0x0004	ON:0x0001, OFF:0x0000
Sampling rate	0x0005	EX:0x0000,FAST:0x0001, MED:0x0002, SLOW:0x0003
Average number	0x0006	0x0001-0x0010
comparator switch	0x0007	ON:0x0001, OFF:0x0000
comparator gear	0x0008	0x0002-0x0004
Comparator noise	0x0009	OFF:0x0000,HL:0x0001, IN:0x0002
Trigger source	0x000A	0x0000-0x0003: INT MAN, EXT, BUS
Trigger delay	0x000B	0-9999

Resistance upper limit 1H	0x000C	IEEE32 format
Resistance upper limit 1L	0x000D	IEEE32 format
Resistance upper limit 2H	0x000E	IEEE32 format
Resistance upper limit 2L	0x000F	IEEE32 format
Resistance upper limit 3H	0x0010	IEEE32 format
Resistance upper limit 3L	0x0011	IEEE32 format
Resistance upper limit 4H	0x0012	IEEE32 format
Resistance upper limit 4L	0x0013	IEEE32 format
Voltage upper limit 1H	0x0014	IEEE32 format
Voltage upper limit 1L	0x0015	IEEE32 format
Voltage upper limit 2H	0x0016	IEEE32 format
Voltage upper limit 2L	0x0017	IEEE32 format
Voltage upper limit 3H	0x0018	IEEE32 format
Voltage upper limit 3L	0x0019	IEEE32 format
Voltage upper limit 4H	0x001A	IEEE32 format
Voltage upper limit 4L	0x001B	IEEE32 format
Zero	0x0020	1: Zero

### 11.1.2 Input register

Name	Address	Value
Resistance value H	0x1001	IEEE32 floating point format
Resistance value L	0x1002	IEEE32 floating point format
Voltage value H	0x1003	IEEE32 floating point format
Voltage value L	0x1004	IEEE32 floating point format
Resistance measurement results	0x1005	IEEE32 floating point format

Voltage measurement results	0x1006	IEEE32 floating point format
-----------------------------	--------	------------------------------

The results show that:

0: OFF 1: IN 2: HI 3: LO

## 11.2 MODBUS instructions

### 11.2.1 Read hold register instruction (0x03)

Request frame		
Address code	0x01~0xFF	1 byte
Instruction code	0x03	1 byte
Starting register address		2 bytes
Number of registers		2 bytes
CRC Verification Code		2 bytes

Normal Response Frame		
Address code	0x01~0xFF	1 byte
Instruction code	0x03	1 byte
Number of bytes		1 byte
Input register		n bytes
CRC Verification Code		2 bytes

Abnormal Response Frame		
Address code	0x01~0xFF	1 byte
Exception code	083	1 byte
Error code	01-04	1 byte
CRC Verification Code		2 bytes

Examples:

Read the instrument resistance range + voltage range (instrument address is 01)

Sending: 01 03 0002 0002 65CB

Instrument return: 010304000400017A32

The resistance range of the instrument is 0004 and the voltage range is 0001

### 11.2.2 Read input register instruction (0x04)

Request frame		
Address code	0x01~0xFF	1 byte
Instruction code	0x04	1 byte
Starting register address		2 bytes
Number of registers		2 bytes
CRC Verification Code		2 bytes

Normal Response Frame		
Address code	0x01~0xFF	1 byte
Instruction code	0x04	1 byte
Number of bytes		1 byte
Input register		n bytes
CRC Verification Code		2 bytes

Abnormal Response Frame		
Address code	0x01~0xFF	1 byte
Exception code	084	1 byte
Error code	01-04	1 byte
CRC Verification Code		2 bytes

Examples:

Read the resistance and voltage values tested by the instrument

Sending: 01 04 1001 0004 A4C9

Instrument return: 010408E7D49B3E260A9D3FC98A

A resistance value of 0.304Ω, a voltage of 1.2269

Note: the data returned by the instrument is in IEEE format.

Reference is made to the appendix for IEEE format

### 11.2.3 Write register instructions (0x10)

Request frame		
Address code	0x01~0xFF	1 byte
Instruction code	0x10	1 byte
Starting register address		2 bytes
Number of registers		2 bytes
Number of bytes		1 byte
Register value		N bytes
CRC Verification Code		2 bytes

Normal Response Frame		
Address code	0x01~0xFF	1 byte
Instruction code	0x10	1 byte
Starting address		2 bytes
Number of registers		2 bytes
CRC Verification Code		2 bytes

Abnormal Response Frame		
Address code	0x01~0xFF	1 byte
Exception code	0x90	1 byte
Error code	01-04	1 byte
CRC Verification Code		2 bytes

Examples:

Set instrument resistance range 10 mΩ voltage range 60 V (instrument address 01)

Sending: 01 10 0002 0002 0001 0001 E276

Instrument return: 011000020002E008

Instrument setup successfully

#### 11.2.4 Trigger instrument test instructions (0x74)

Request frame		
Address code	0x01~0xFF	1 byte
Instruction code	0x74	1 byte
CRC Verification Code		2 bytes

Normal Response Frame		
Address code	0x01~0xFF	1 byte
Instruction code	0x74	1 byte
Number of bytes		1 byte
Input register		n byte
CRC Verification Code		2 bytes

Examples:

Read the resistance and voltage values tested by the instrument

Sending: 01 74 00 07

Instrument return: 017408E7D49B3E260A9D3FC98A

A resistance value of 0.304Ω, a voltage of 1.2269

## Appendix: Data representation format for IEEE32 floating-point, signed integers

IEEE32 is the floating point representation developed by the International Electrotechnical Commission, the main thing is to use four bytes to represent floating point numbers, the negative range of the data that can be represented is  $-2 \times 2^{128} \sim -2^{-127}$ ,  $2^{-127} \sim 2 \times 2^{128}$ . As shown below, A high (bit31) symbol bit (0 positive, 1 negative) for a floating point number; bit30-bit23 these eight bits represent the order code of the floating point number (bottom 2), Range 0- FF( hexadecimal), 7 F for order 0, 80 means 1, 7E the order is -1, And so on. bit22-bit0 represents the decimal part of the Mantissa of a floating-point number, the integer part of the Mantissa is always 1.

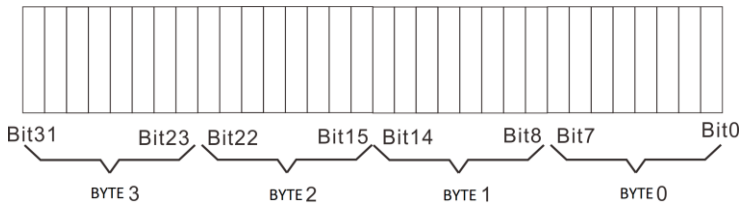

An example is given to illustrate the representation of IEEE32 floating point numbers, assuming there's a IEEE32 float now, The binary format is 010000101 11001000 00000000 00000000, According to the above rules, the order code should be 10 000 101, or 0X85, The decimal part of the Mantissa is 0.1001 in binary, In decimal ,0.5625, Since the integer portion of the Mantissa is always 1 by default, So the value of the float should be  $+1.5625 \times 2^{85-7F} = 100$ .

Because IEEE32 floating-point numbers can represent a large range of data in only 4 bytes, they are often used in communication to improve communication efficiency. IEEE32 floating-point numbers are used more in binary communication. When a I/O device uses a INTEL company's CPU, it must be sent in bytes 0, byte 1, byte 2, byte 3, whether the I/O device sends a



floating point number to the PC device or the PC device to the I/O device. If the I/O device uses the company's CPU, data, the order of transmission is the opposite. As this is not absolute, it represents only the majority of cases, and when it comes to data formats, the manual for the use of I/O equipment should first prevail.

#### 16-bit and 32-bit signed integers

16-bit and 32-bit signed integers use the highest bit as the symbol bit ,0 for positive number ,1 for negative number, negative numbers are represented by complement codes, The 16-bit signed integer, for example, should be a complement of 100, that is, a complement of 0X64 is XFF9C.



This specification is edited and revised by HOPETECH Technology Department, version number V2.2.

If the specification is incorrect or unreasonable, please contact us. Welcome to call for technical consultation.

Manufacturer: Changzhou HOPETECH Electronic Technology Co., Ltd  
Address :5/F, Block A ,88 Taihu West Road, Xinbei District, Changzhou  
Tel: 0519-89852525      Fax: 0519-89853517

Website: [www.hopetech.cn](http://www.hopetech.cn)

- If contact information changes, please pay attention to our website.
- The copyright and interpretation of this specification are owned by our company.