

---

Programmable voltage withstand insulation

tester

User's Manual

9910

---

---

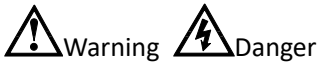
## Safety Tips



When the following abnormal situations occur, do stop operating and turn off the power immediately, otherwise, fire and electric shock would be caused. Call your dealer or Hope Electronics representative for help.

- Improper device operation
- Abnormal noise, odors, smoke or flash occurred in operation
- The device produces a high temperature or electric shocks during the operation
- Damage of power cord, power switch or power socket
- Impurities or liquid enter the device

## Safety Information



Mishandling during using could result in injury or death, as well as damage to the product. Be certain that you understood the instructions and precautions in the manual before use.

<b>Disclaimer</b>	Before using the product, be sure to carefully read the following safety notes. If users do not observe the following instructions, Hope Electronic Science and Technology will not blame for any of users' loss.
<b>Instrument grounding.</b>	In order to avoid electric shock, please ground the instrument.
<b>Avoid using instrument in the environment with explosive gas</b>	Avoid using the instrument in the environment with explosive gas, vapor or dust environment. Using any electronic instrument in such environment is dangerous.
<b>Do not open the instrument cover</b>	Only authorized service personnel should remove the cover and have internal access to the instrument for repairing. The instrument still has residual charge, which may cause electric shock, after it's shut down in a period of time.
<b>Do not use damaged the instrument</b>	If the instrument has been damaged, the risk will be unpredictable. Please disconnect the power cord and no longer use the instrument. Do not attempt to maintenance the device by yourself.
<b>Do not use unusual instrument work</b>	If the instrument is not working properly, the risk will be unpredictable. Please disconnect the power cord and no longer use the instrument, Do not attempt to maintenance the device by yourself.
<b>Do not exceed the designated use of instrument in manual</b>	Beyond the scope, the protection of instrument provided will be ineffective.

---

9910

Programmable voltage withstand insulation tester

# Operation manual

Simplified Chinese

Oct, 2021

Rev5.2

k

Hope Technologies., Ltd

---

## Limited Security and Responsibility Scope

Hopetech Electronics Technology Co., Ltd ensure that each CHT9910 you purchased is fully qualified in terms of quality and measurement. This guarantee does not include fuses.

Hopetech Electronics commits that the instrument has no defects in materials and process, such as product quality problems under warranty. If the product is proved to be defective, Hope Electronics will repair or replace it free of charge.

Since the date of delivery, Hope Electronics commits that the product has two years guarantee, while other accessories have one year. Under warranty, any failure of hardware or software of the product will be due to the quality of the product itself. Users provide the product warranty and maintenance card to get free maintenance which provides from the maintenance department or its authorized maintenance agent of Hope Electronics. Any maintenance beyond the warranty period should be at user's own expense.

For free maintenance product, Hope Electronics commits that it would be repaired and returned to customer within five working days on receipt of the equipment unless otherwise specified. Hope Electronics affords the cost of the return transportation.

Any of the following circumstances occurred; Hope Electronics will not repair for free.

- 1) Accidental damage caused by transportation
- 2) Improper installation or instrument failure or damage is caused by non-use work environment
- 3) Artificial damage to the appearance of the products (such as surface scratches, deformation, etc.)
- 4) Unauthorized repair, alteration, replacement of instrument and product has been tearing up the warranty seal
- 5) The fault or damage is caused by irresistible factors (such as lightning strikes)
- 6) Directly or indirectly damage is caused by improper operation of the user

If mismeasurement or immeasurable is caused by the improper operation of the user, but not the problem of the instrument itself, the cost of transit should be paid by user.

---

## Table of Content

Safety Tips .....	3
Safety Information .....	3
Limited Security and Responsibility Scope .....	5
Chapter 1 Safety Rules .....	8
1.1 General provisions .....	8
1.2 Care and Maintenance .....	9
1.2.1 User maintenance .....	9
1.2.2 Regular maintenance .....	9
1.2.3 User Modification .....	9
1.3 Test environment .....	9
1.3.1 Work Location .....	9
1.3.2 Input Power .....	9
1.3.3 Workplace .....	10
1.4 Operator Regulations .....	10
1.4.1 Qualification of personnel .....	10
1.4.2 Safety Rules .....	10
1.4.3 Dress Code .....	10
1.4.4 Medical Regulations .....	10
1.5 Test Security Procedural Requirements .....	11
1.6 Security Points .....	11
Chapter 2 Security Rules Introductions .....	12
2.1 Testing Importance .....	12
2.2 Withstand voltage test .....	12
2.3 Advantages and disadvantages of AC test and DC test .....	13
2.3.1 AC withstand voltage (ACW) test features as well as advantages and disadvantages .....	13
2.3.2 DC testing features as well as advantages and disadvantages .....	14
2.4 Insulation Resistance Test .....	14
Chapter 3 Technical Specification .....	16
3.1 Product introduction .....	16
3.2 AC withstand voltage test parameters .....	16
3.3 DC voltage withstand test parameters .....	错误!未定义书签。
3.4 Test parameter of insulation resistance .....	错误!未定义书签。
Chapter 4 Instrument recognition .....	17
4.1 Front panel construction .....	17
4.1.1 Schematic of the front panel .....	17
4.1.2 Front panel description .....	17
4.2 Rear panel construction .....	18
4.2.1 Schematic of the rear panel .....	18
4.2.2 Back panel description .....	18
4.3 Instrument size .....	20
Chapter 5 Procedures and procedures .....	21
5.1 Operating instructions .....	21
5.2 Operation Procedure .....	21
Chapter 6 Remote input and output signal .....	24
6.1 Input and output signals .....	24
6.2 Remote control output signal wiring and instructions .....	24
6.3 Instruction for remote input signal wiring .....	24
Chapter 7 Automatic discharge circuit .....	25
7.1 Discharge principle .....	25
7.2 Points to note .....	25
Chapter 8 Test parameter setting .....	26
8.1 Specification of test parameters .....	26
8.2 Measurement parameter setting .....	28
Chapter 9 System parameter setting .....	37
9.1 System Specification .....	37

---

9.2 System parameter setting .....	37
Chapter 10 User Zeroing calibration .....	40
10.1 User zeroing instructions .....	40
10.2 Use the user zero function.....	40
Chapter 11 Maintenance Guide.....	42
11.1 Routine maintenance.....	42
11.2 Simple fault handling .....	42
11.3 Quality Assurance .....	42

---

# Chapter 1 Safety Rules

---



Thank you for purchasing our products. Please read this manual before use, and keep it handy for future reference.

Regulations and matters needing attention before high voltage test!

In this chapter you will learn the following:

- General provisions
  - Care and maintenance
  - Test environment
  - Operator regulations
  - Test safety procedures
  - Safety points
- 

## 1.1 General provisions

Before using this tester, please read the instructions carefully to understand the operating procedures and related safety notes to ensure safety.

Before turning on the input power switch of this tester, please select the correct input voltage (110V or 220V) specifications.



**Danger** indicates high voltage output, do not contact.



**Ground** indicates chassis ground symbol

**WARNING**

**WARNING** indicates a potentially hazardous situation that will result in death or serious injury to the operator.

The voltage and current generated by the tester are sufficient to cause personal injury. In order to prevent accidental injury or death, be sure to observe the tester clearly before proceeding it.



---

## **1.2 Care and Maintenance**

### **1.2.1 User maintenance**

To prevent electric shock, non-professionals should not open the cover of the instrument. All parts inside the instrument must not be changed without permission. If an abnormality occurs to the instrument, please seek the help of Hopetech authorized distributor.

### **1.2.2 Regular maintenance**

This series of Tester, input power cords, test leads and related accessories must be carefully inspected and calibrated at least once a year to ensure the safety of the operator and the accuracy of the instrument.

### **1.2.3 User Modification**

The user must not modify the wiring or parts of the instrument, otherwise the company's warranty will be invalidated and will take no responsibility for the consequences caused by the modification.

## **1.3 Test environment**

### **1.3.1 Work Location**

When operating this instrument, make sure that the instrument is placed in a place where ordinary personnel cannot touch it at will. If this is not possible in your production line site, the test area must be isolated from other facilities and a " HIGH-VOLTAGE TEST WORK AREA " must be marked. If high-voltage test work area is very close to other work areas, special attention must be paid to safety. During the high voltage test, it must be marked "DANGER! ! HIGH-VOLTAGE TEST IN PROCESS, DO NOT ENTER, AUTHORIZED PERSONNEL ONLY "

### **1.3.2 Input Power**

The tester must be well grounded, and the ground wire must be connected before testing to ensure the safety of the operator. The test zone power supply must have a separate switch installed at the entrance of the test zone to ensure that everyone can identify it. In case of emergency, the power switch can be turned off immediately.

---

### **1.3.3 Workplace**

Use a workbench made of non-conductive material as possible as you can. Do not use any metal between the operator and the test object. The operator must not be across the object under test to operate or adjust the tester. If the object volume is small, it is better to place it in a non-conductive box.

The test site must be kept tidy and clean at all time. Do not use this tester near flammable materials. Place unused tester and test leads in a fixed position. Make sure that all personnel can immediately tell the object under test, object to be tested, and tested object.

The test area and the surrounding air must not contain flammable gases, and the tester should not be used near flammable materials.

## **1.4 Operator Regulations**

### **1.4.1 Qualification of personnel**

The voltage and current output by the tester will result in death or serious injury to the operator. The tester must be used and operated by trained and qualified personnel.

### **1.4.2 Safety Rules**

Operators must be educated and trained regularly to understand the importance of various operating rules and operate the tester in accordance with safety rules.

### **1.4.3 Dress Code**

Operators are not allowed to wear clothes with metal decoration or metal bracelets and watches, which are easy to make an accidental electric shock. The consequences are even more severe when you get an electric shock.

### **1.4.4 Medical Regulations**

The tester must not be operated by a person with a heart attack or with a pacemaker.

---

## 1.5 Test Security Procedural Requirements



---

**Forbidden to be used in charged circuit board or device!**  
**Forbidden to touch the tested object and any connected!**

---

The earth lead must be connected according to requirements. Connect the measured end to DUT (Device Under Test) while linking. Holding wire only can be lead into output before testing. Only insulating parts can be picked up, no gripping to conductor. Operator must be determined to be capable to operate independently, others are forbidden to control the switch and remote control switch. Put remote control switch in a fixed place.

## 1.6 Security Points

- Non-qualified operators and non related personnel should stay away from the test area.
- Maintain a safe and orderly state in test area.
- Forbidden to touch tested object or any connected.
- Turn off the current output and output power in case of any problems.
- After DC voltage withstand test and insulation resistance test, discharge operation must be carried out before dismantling the test line.

---

# Chapter 2 Security Rules Introductions

---



In this chapter, you will learn:

- Testing Importance
  - Withstand voltage test
  - Advantages and disadvantages of AC test and DC test
  - Ground Resistance Testing
- 

## 2.1 Testing Importance

The manufacturer must try to their best to improve the safety of instrument and avoid operator's electrical shock, even in case of error operation. Security testing is necessary to achieve general acceptance of security requirements. Present safety execution units, such as UL, CSA, IEC, BSI, VDE, TUV, and JSI etc., all require manufacturers take safety testing by grounding continuity test instrument in products design and production.

## 2.2 Withstand voltage test

If a product can work in a very harsh environment, you can be sure that it will work in a normal environment. The most commonly used withstand voltage tests are:

- Functional testing at design time -- ensures that the designed product meets its functional requirements.
- Specification testing in production -- Make sure that the products can meet the requirements of the specifications.
- Quality Assurance confirmation test -- Make sure the quality of the product can meet the safety standard.
- Safety test after maintenance -- Make sure that the product can be maintained to safety standard after repair.

Different products have different technical specifications, basically in the withstand test is a higher than normal working voltage on the product test, this voltage must be sustained for a period of time. If the leakage current of a component is kept within the specified range for a specified period of time, it can be determined that the component is working under normal conditions and should be very safe. And good design and selection of good insulation materials can ensure that users are protected from electric shock.

The voltage withstand test done by the instrument, generally known as "high voltage dielectric test", referred to as "voltage withstand test". The basic requirement is  $2 * \text{the operating voltage of the object under test} + 1000\text{V}$  as the voltage standard for the test. The test voltage of some products may be higher than  $2 * \text{working voltage} + 1000\text{V}$ . For example, some products have operating voltages ranging from 100V to 240V, and test voltages for these products may be between 1000V and 4000V or higher. In general, products with a

---

“double insulation”; design may use test voltages higher than the standard of 2 \* operating voltage of 1000V.

The withstand voltage test is more precise in product design and sample making than in production, because the safety of the product is determined at the design and test stage. Although only a few samples are used in the design of the product, the on-line test should strictly require all products to pass safety standards to ensure that no defective products will flow out of the production line.

The output voltage of the withstand voltage tester must be kept within the range of 100% to 120% of the specified voltage. The output frequency of the AC withstand voltage tester shall be maintained between 40 and 70 Hz, and its peak value shall not be less than 1.3 times the RMS voltage, and its peak value shall not be more than 1.5 times the RMS voltage.

## **2.3 Advantages and disadvantages of AC test and DC test**

Please confirm with the specified safety and regulation unit of the product under test what voltage should be used for the product. Some products can accept both DC and AC test options, but there are still many products that are only allowed to be tested in one DC or AC mode. If the safety specification allows for both DC and AC testing, the manufacturer can decide for itself which tests are more appropriate for his product. To achieve this, the user must understand the advantages and disadvantages of both DC and AC tests.

### **2.3.1 AC withstand voltage (ACW) test features as well as advantages and disadvantages**

FEATURES: Most of the voltage withstand test objects will contain some stray capacitance. It may not be possible to fill these stray capacitors with an AC test and a continuous current will flow through them.

PROS: 1. In general, the AC test is more acceptable than the DC test. The main reason is that most of the products are using AC, and AC testing can be positive and negative polarity of the product testing, and product use environment is completely consistent with the actual use of the situation.

2. Since the stray capacitance can not be filled during the AC test, but there is no instantaneous impulse current, so the test voltage does not need to rise slowly and can be added at the beginning of the test, unless the product is sensitive to impulse voltage.

3. Since the AC test can not be filled with those stray capacitors, there is no need to discharge the test object after the test.

CONS: 1. If the stray capacitance of the object under test is large or the object under test is a capacitive load, the current generated will be much larger than the actual leakage current, so

---

the actual leakage current can not be known.

2. Since the stray capacitance of the object to be measured must be supplied, the output current required by the instrument will be much higher than when the DC test is used. This increases the risk to the operator.

### 2.3.2 DC testing features as well as advantages and disadvantages

Features: in DC withstand voltage test, the test object on the stray capacitance is filled, DC withstand voltage test caused by the capacitive current, after the stray capacitance is filled, will be reduced to zero.

PROS: 1. Once the stray capacitance of the test object is filled, only the actual leakage current of the test object remains. DC voltage withstand test can clearly show the actual leakage current of the object to be measured.

2. The current capacity of the instrument is much lower than that required for the AC withstand test, since only a short period of time is required to supply the charging current of the object under test and the current required at other times is very small.

CONS: 1. Unless there is no capacitance present on the test object, the test voltage must start from zero and rise slowly to avoid excessive charging current. The higher the capacitance, the longer the rise time, and the lower the voltage that can be increased at one time. When the charging current is too high, it will cause the misjudgment of the Tester and make the test result incorrect.

2. Because DC withstand voltage test will charge the test object, so after the test, must first test object discharge, to do the next work.

3. Unlike the AC test, the DC withstand voltage test can only be a single polarity test, if the product is to be used under the AC voltage, this disadvantage must be considered. This is why most safety regulators recommend the use of AC voltage withstand tests.

4. In the AC test, the peak voltage display is 1.4 times the ammeter, which is the general ammeter can not display, but also DC withstand voltage can not be achieved. Therefore, most ampere gauge units require that, if a DC withstand test is to be used, the test voltage must be increased to an equal value.

## 2.4 Insulation Resistance Test

Insulation Resistance Test is mainly used to measure the resistance between the fire wire and the casing. The measuring method is based on Ohm's law, adding a voltage between the fire wire and the casing, then measuring the voltage and current value respectively, and then calculating the resistance value according to OHM's law. Usually a large constant voltage (DC 500V or 1000V) is applied and maintained for a specified period of time as the test standard.

---

If the resistance is kept within the specified specifications for a specified period of time, it can be determined that the appliance should be relatively safe to operate under normal conditions.

The higher the insulation resistance value, the better the insulation of the product. The insulation resistance measured by the insulation resistance test is the equivalent resistance formed by the connected networks between the two test points and their surroundings.

However, insulation testing failed to detect the following conditions:

- The insulation is too weak;
- there are pinholes in the insulator;
- the parts are not far enough apart;
- the insulator is crushed and broken;

all these conditions can only be detected by the voltage test.

---

# Chapter 3 Technical Specification

---



In this chapter you will learn the following:

- Product introduction
  - Test parameter
- 

## 3.1 Product introduction

99XX series voltage withstand insulation tester is used to test the safety parameters of electronic products. Can Be used for household appliances, electronic instruments, electronic equipment, electronic components, wires and cables and other electrical products voltage and insulation testing.

This series of products have qualified/unqualified discrimination function, sound and light alarm function and test time automatic control function, simple operation, beautiful appearance, fast cut-off speed and so on. It is an ideal test instrument for withstand voltage and insulation.

## 3.2 AC withstand voltage test parameters

Accuracy:  $\pm$  (reading error + range error)

Model number		9910
Voltage output		
AC	Output voltage range	0.01kV to 5.000kV
	Accuracy of output voltage	$\pm(3\%+0.1\%FS)$
	Output Voltage resolution	0.001kV
	Maximum rated power output	60VA (5000V12mA)
	Maximum output current	12mA
	Output waveform	Sine wave (1.3< Crest factor <1.5)
	Output Frequency	50Hz or 60Hz
	Output waveform distortion	$\leq\pm 3\%$ (No load or load with pure resistance)
	Rate of voltage rise	MAX 4000V/1S
Voltage display		
AC	Measuring range	0.01kV to 5.000kV
	Display resolution	0.001kV
	Measuring accuracy	$\pm(3\%+0.1\%FS)$
	Display value	Root mean square value
Current display		
	Measuring range	0.00mA to 12.00mA
	Display resolution	0.01mA



AC	Measuring accuracy	$\pm(3\%+0.2\%FS)$	
	Display value	Root mean square value	
Parameter setting			
Judgment Function	AC	Upper limit setting	0.01mA to 12.00mA
	AC	Lower bound setting	0.00mA to 11.99mA
Timing function	Rise time		0.1S to 999.9S
	Test Time		0.1S to 999.9S
	Time resolution		0.1S

## Chapter 4 Instrument recognition

### 4.1 Front panel construction

#### 4.1.1 Schematic of the front panel

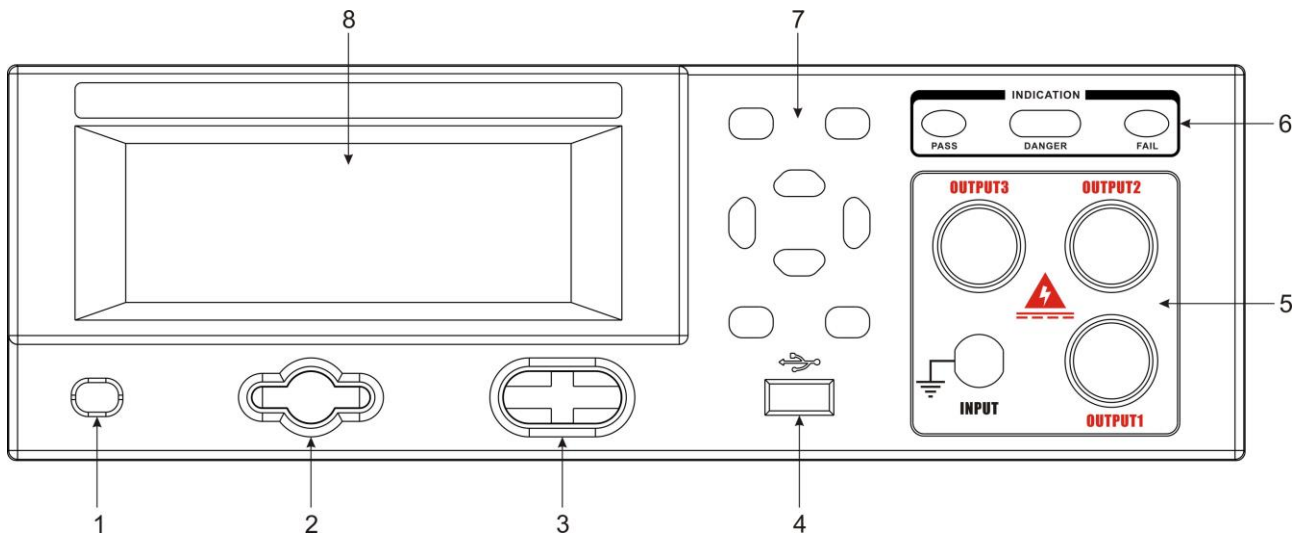


Figure 4.1 front panel schematic

#### 4.1.2 Front panel description

1. Power switch



Power on



Power off

2. Activate test button

As the starting switch of the test voltage output;

3. Stop Test Button (reset)

➤ When the test is in progress, it can be used as a switch to interrupt the test;

- At the end of the test, as the exit test display into the next state to be tested switch;
4. USB interface
    - USB interface for exporting data;
    - USB scanning gun interface, used to record product Bar Code;
  5. Test Terminal
    - OUTPUT High-voltage output
    - INPUT Current Return Terminal
  6. Indicator light
    - PASS: Test qualified indicator light;
    - DANGER: High Voltage output indicator lamp;
    - FAIL: Failed test indicator.
  7. Key area
    - In the machine to be tested state can be through the region of the key to operate.
  8. LCD display screen
    - 192 \* 64 Character Dot Matrix backlit liquid crystal display for displaying set data or test results.

## 4.2 Rear panel construction

### 4.2.1 Schematic of the rear panel

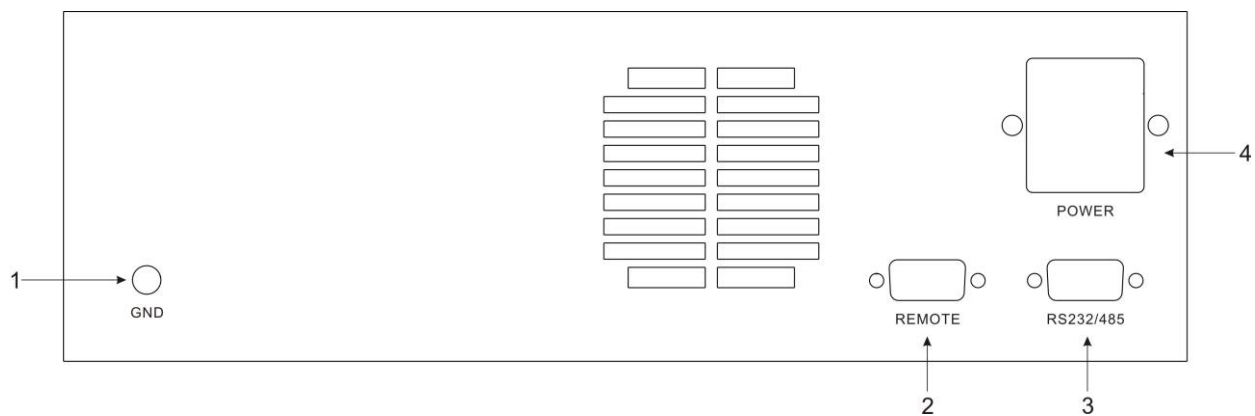


Figure 4.2 Rear panel schematic

### 4.2.2 Back panel description

#### 1. Earthing terminal

The grounding terminal of the machine body, please connect the grounding wire properly to ensure the safety of the operator.

#### 2. Remote Signal Terminal

It's a standard 9pin D terminal block. Provide normally open (N. O.) contacts for remote monitoring signals for PASS, FAIL, and PROCESSING, and control contacts for TEST, startup, and RESET.

---

3. Serial Communication Port

Is a standard 9PIN D terminal block that provides RS232 or RS485 communication.

4. Input socket

Standard input power outlet to provide working power for the instrument.

### 4.3 Instrument size

The dimensions are as follows:

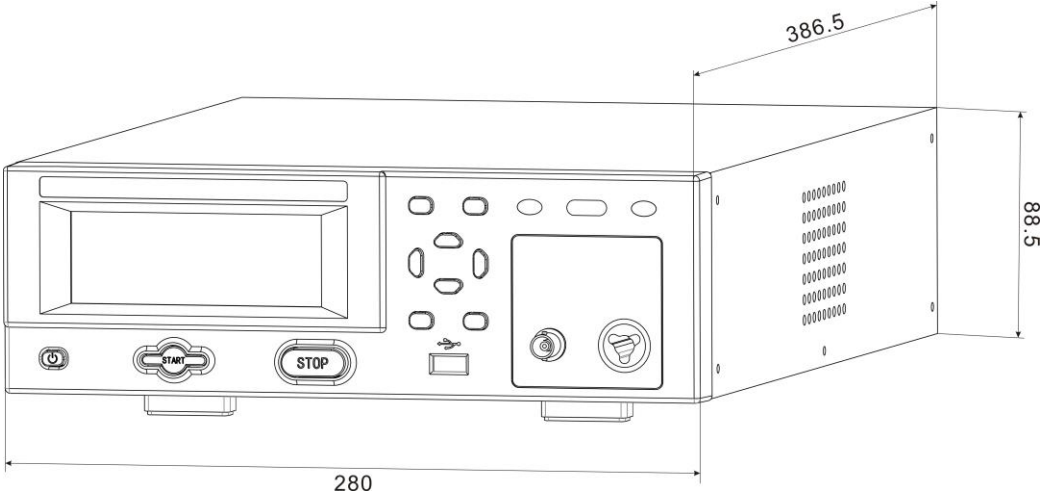


Figure 4.3 case size diagram

---

# Chapter 5 Procedures and procedures

## 5.1 Operating instructions

This series of withstand voltage insulation tester is mainly for general production line or quality inspection use, its operation and settings are very simple. Unreasonable setting and operation, will not respond.

## 5.2 Operation Procedure

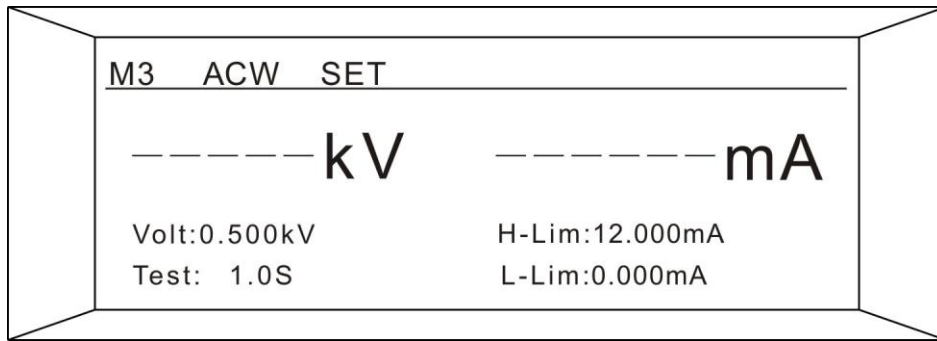
Please follow the steps below to operate the device:

1. Please switch off the input “power switch” of this instrument and switch the “voltage select” switch on the back panel to the correct input voltage position before connecting the input power cord plug of this instrument to the city power supply, at the same time check the specifications of the fuse is correct. Then connect the ground wire to the “ground end” on the back panel of the instrument.
2. Connect the input power cord to the power outlet of the instrument. Please do not connect the high voltage test cord to the high voltage output terminal of the instrument.
3. Connect all the test lines of the test object, then connect the circuit to the test terminal of the instrument, finally connect the high-voltage test line to the high-voltage terminal of the instrument, and check whether all the test lines are connected properly.
4. Open the input “power switch” of this instrument, the boot interface is as follows:

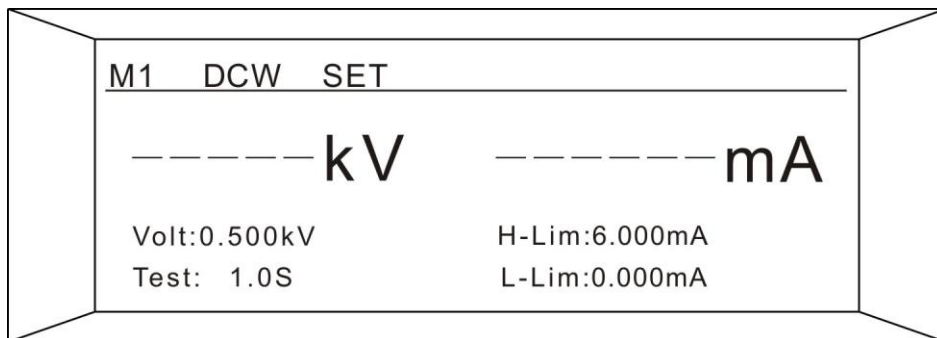


Figure 5.1 boot interface

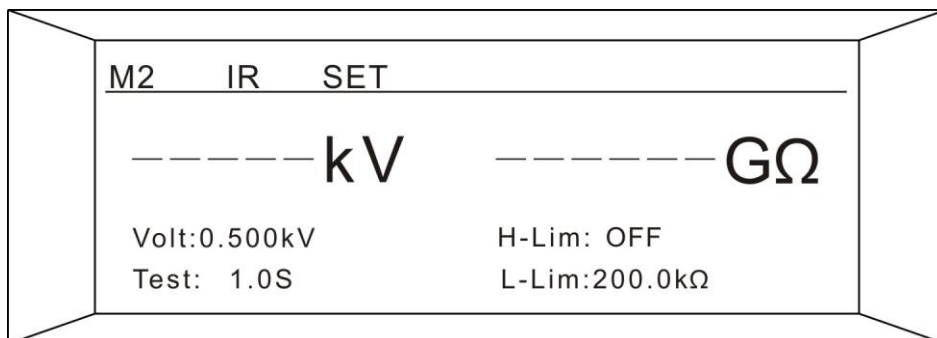
5. After the BOOT is complete, the instrument will save the last shutdown test group number and mode. And enter the test and parameter setting mode, this time the display will appear:



5.2 interface to test and communicate



5.3 interface for DC test



5.4 Insulation Resistance Test Interface to be tested

If you want to reset the test parameters, press the SET key, parameter settings, detailed settings and steps, please refer to the “test parameter settings” instructions.

5. Press the START button to output the voltage, while the DANGER light flashes on the panel and the timer starts. Do not touch the object under test while the test is in progress.

6. When the test is finished, the output of the instrument will be automatically turned off. If the test passes, the “PASS” green light will light up and emit a “beep, beep” sound to confirm that the test object passed the test and the test results are satisfactory. The LCD display will display the “PASS” and test results data. If the test fails, the “FAIL” red indicator lights up and beeps until any key is pressed, confirming that the test item passed the test and the test comparison failed, the LCD display will display “FAIL” and test result data. Press the “STOP” switch, and the program immediately clears the test results and returns to the interface to be

---

tested.

7. If you want to STOP the test during the test, please press the “STOP” switch, the instrument will STOP the test immediately, the monitor will retain the test value at that time. To continue the test, press the “STOP” button to return to the test interface, and then the “START” button to START the test. Or press the “START” button directly to START.

8. If the test object fails, the instrument will stop the test immediately and the display will display its status and the value of the failure. The Red “FAIL” indicator will be on at this time, and a “beep” will continue to sound. You can press the “STOP” button to turn off the alarm sound, and then press the “start” switch to continue the test. For information about the display of various LCD screens, refer to the “display information” section.

9. To operate the Tester with an external remote control, connect the remote control to the remote input terminal on the back panel. The function and function of the TEST and RESET switch on the remote controller is the same as that of the start and RESET switch on the front panel of this instrument. Since the starting and RESET switches of this instrument and the TEST and RESET switches of the remote controller can be operated at the same time, the remote controller must be kept in good condition.

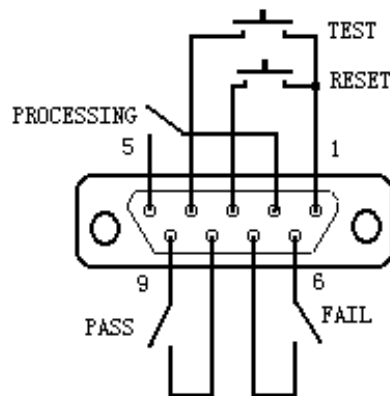
10. This tester has the outputs of PASS, FAIL, and PROCESSING monitoring signals, which can be sent to the Control Center for Monitoring, and the instrument can be monitored remotely.

---

# Chapter 6 Remote input and output signal

## 6.1 Input and output signals

A remote monitoring and remote control terminal is attached to the back panel of the Tester, which can connect the working status of the Tester to the Monitoring Center for Monitoring, and can be connected to the remote controller for operation. This terminal is a standard 9PIN D terminal block. It contains PROCESSING, PASS, FAIL, and two remote control inputs, TEST and RESET.



## 6.2 Remote control output signal wiring and instructions

This tester provides three “normally on” (N. O.) contact signals, each is supplied by three relays within the instrument, with a capacity of AC125V L. 0A/DC125V 0.5 a. these contacts have no positive or negative polarity limits, and each signal is individually wired with no common ground. The terminal block is marked with the pin number. The wiring of the output signal is as follows:

- ✧ Processing Signal: The output signal is connected between PIN2 and PIN5.
- ✧ Pass Signal: The output signal is connected between PLN8 and PIN9.
- ✧ Fail Signal: The output signal is connected between PLN6 and PIN7.

## 6.3 Instruction for remote input signal wiring

This tester is equipped with remote control contact, can be operated by external remote control device TEST (start) and RESET (RESET) function of the instrument. The “instantaneous contact” switch must be used as the controller. Please pay special attention, must not be connected to any other power supply, if connected to other power supply, will cause the instrument internal circuit damage or misoperation. The terminal block is marked with the pin number. The detailed wiring is as follows:

1. Test Control: The control switch is connected between PIN1 and PIN4.
2. Reset control: The switch is connected between PIN1 and PIN3.
3. PIN1 is the common ground of the remote operating circuit



---

# Chapter 7 Automatic discharge circuit

## 7.1 Discharge principle

When the test is carried out, especially the DC withstand voltage test, the test object and circuit will retain a lot of power, must first discharge before the test line removal work. After the completion of the test instrument, the program automatically drives the discharge circuit. In the time of 0.2 seconds or so, will be measured on the circuit and the remaining power all discharged. The total capacity of the discharge circuit is as follows:

Maximum discharge capacity:

- 0.2 $\mu$ F ----- When the output voltage is  $\leq 1\text{KV}$
- 0.1 $\mu$ F ----- When the output voltage is  $\leq 2\text{KV}$
- 0.06 $\mu$ F ---- When the output voltage is  $\leq 3\text{KV}$
- 0.05 $\mu$ f --- When the output voltage is  $\leq 4\text{KV}$
- 0.04 $\mu$ f --- When the output voltage is  $\leq 5\text{KV}$
- 0.015 $\mu$ F --- When the output voltage is  $\leq 6\text{KV}$

## 7.2 Points to note

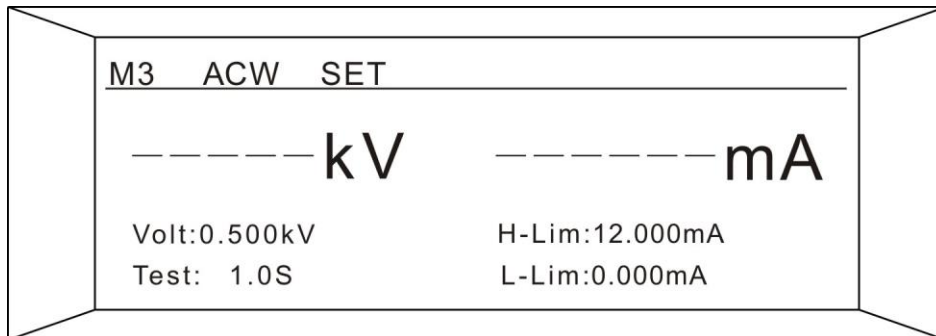
If the output voltage corresponding to the capacity range, automatic discharge circuit will be injured and cause failure, please pay special attention not to exceed the discharge capacity.

Please note that if the input power is turned off, the automatic discharge circuit will not work, the object under test will not be discharged. Do not turn off the input power while testing is in progress.

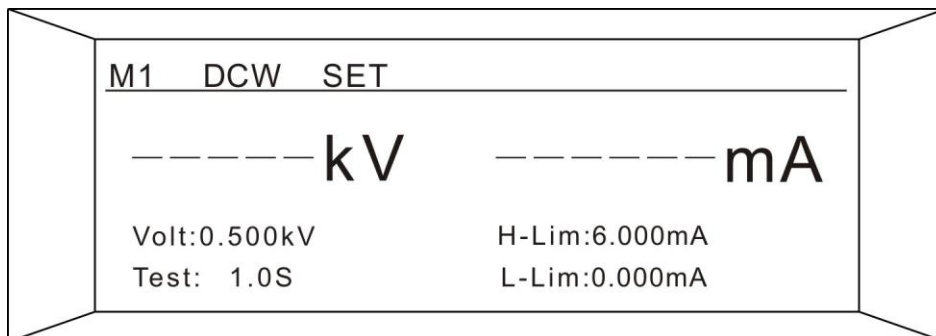
# Chapter 8 Test parameter setting

## 8.1 Specification of test parameters

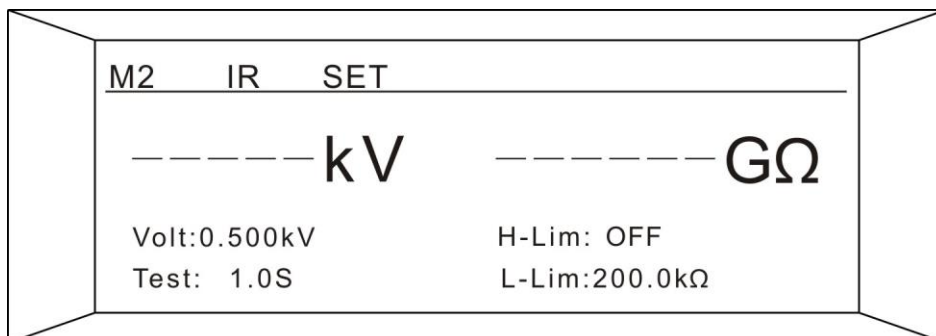
When the power is turned on, the program will automatically enter the last shutdown before the last test set parameters, the liquid crystal display will show:



8.1 Communication Test to be tested interface



8.2 DC test interface



8.3 Insulation Resistance Test Interface to be tested

Note:

- ACW: AC voltage withstand test
- DCW: Represents a DC withstand voltage test
- IR: Represents the insulation resistance test
- SET: A prompt that indicates the current status of a test or parameter setting

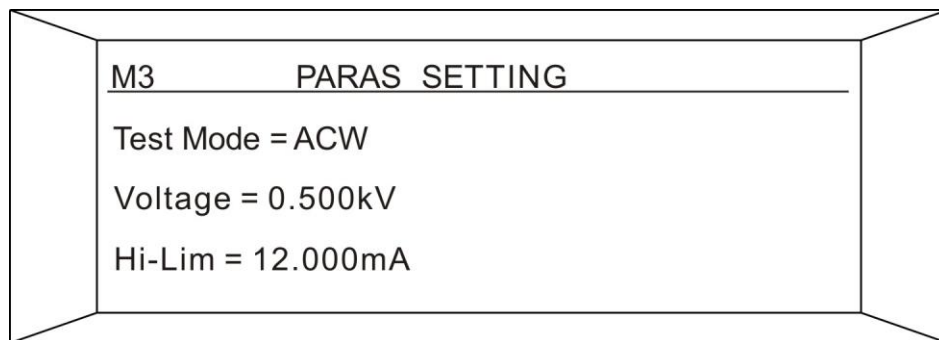
---

Variable description:

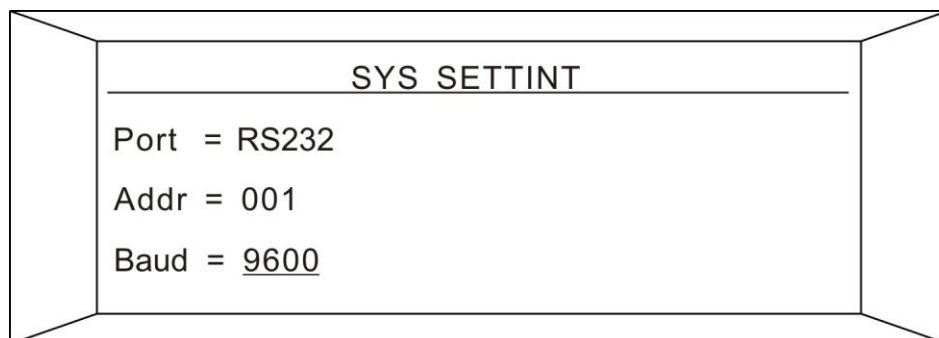
- MX: Parameter Group (1-6)
- ACW DCW IR: Test Mode
- Volt: Set output voltage
- Test: SET The test time
- H-Lim: Upper bound setting
- L-Lim: Lower bound setting

The [SET] key is the parameter item setting key. Each time the [SET] key is pressed in the test and parameter setting mode, the parameter setting is flipped to the next setting item. [ESC] key will automatically set the test parameters stored in memory; the test parameters stored in memory, after the input power is turned off will still be retained and will not be cleared, unless again manually reset.

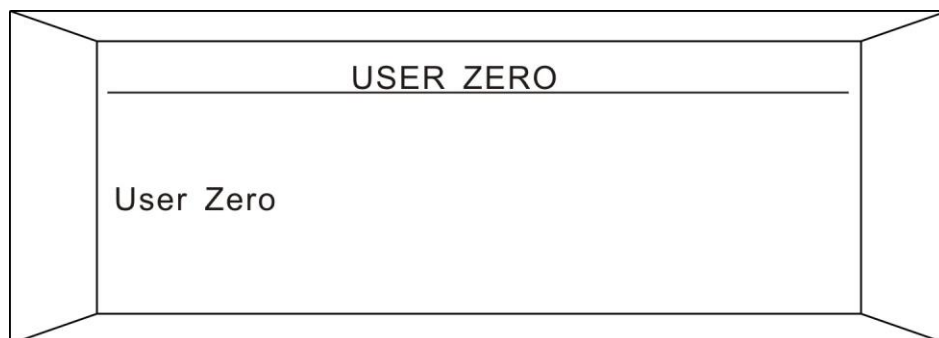
The instrument has a total of 3 settings, with [Set] button can be displayed in a loop. The three settings are as follows:



8.4 Measurement parameter setting interface



8.5 System parameter setting interface



8.6 User reset interface

---

“▲” and “▼” key is the input key for the operation key and parameter value selected as the group.

When setting the output voltage, leakage current or insulation resistance upper limit, leakage current or insulation resistance lower limit, slow rise time, test time, delay judgment time window, press the “▼” Key, the cursor will move to the left and move to the left most digit below, press this button again and the cursor will return to the lower right-most value. When you press the “▲” Key, the value of the cursor will increase by 1. When the value is “9”, then press this key again and the value will become “0” or “. “. When the cursor stops below the unit, you can use the “▲” Key to select the unit.

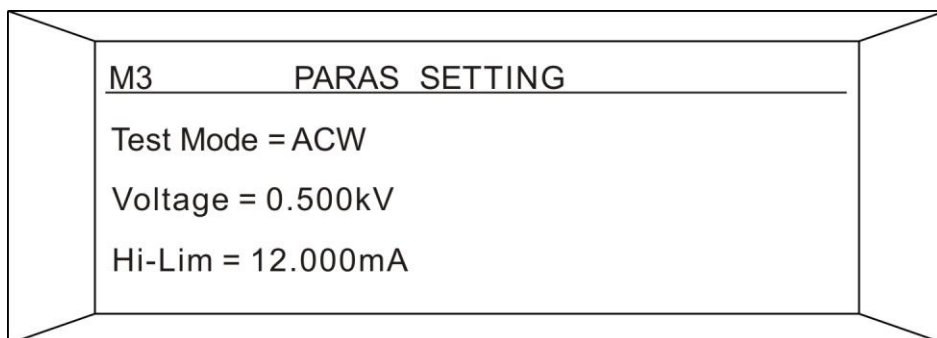
When setting output frequency, ARC sensitivity, connection test, the number will increase when pressing “▲” Key and decrease when pressing “▼” Key. Each time you press “▲” And “▼” Keys, the last number on the display will “increase 1” or “decrease”.

During the course of setting the test parameters, if you don't have to reset all the parameters, you can leave the test parameters setting mode by pressing the [ EXIT ] key after any step is completed, and the program will automatically enter the test mode, and will have set the test parameters stored in memory. Program does not accept unreasonable settings and input, the following parameters set the description of the “x” on behalf of any number between 0-9.

**Note: When the value is SET, press [ SET ] or [ EXIT ] keys do not save and Short Buzzer, you must check whether the input value is within the SET range.**

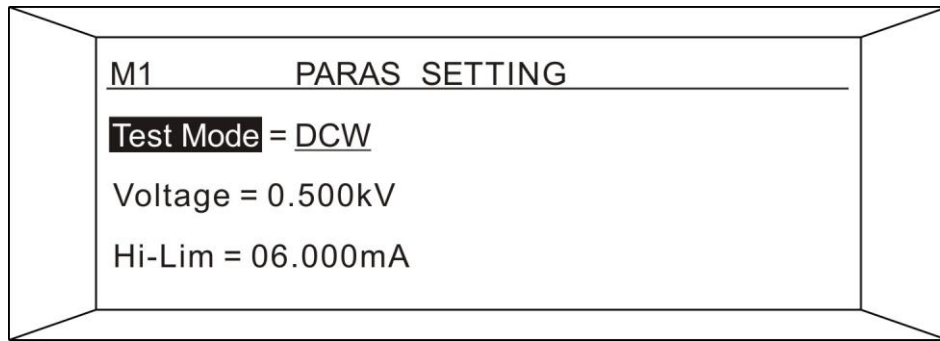
## 8.2 Measurement parameter setting

Under the test interface, press [ Set ] to enter the Set of measurement parameters page, as follows:



8.7 interface for setting measurement parameters

1. Test Mode selection (AC/DC voltage withstand test and insulation resistance test)  
Press the “▲” or “▼” Key to select what you want to set, as shown below.

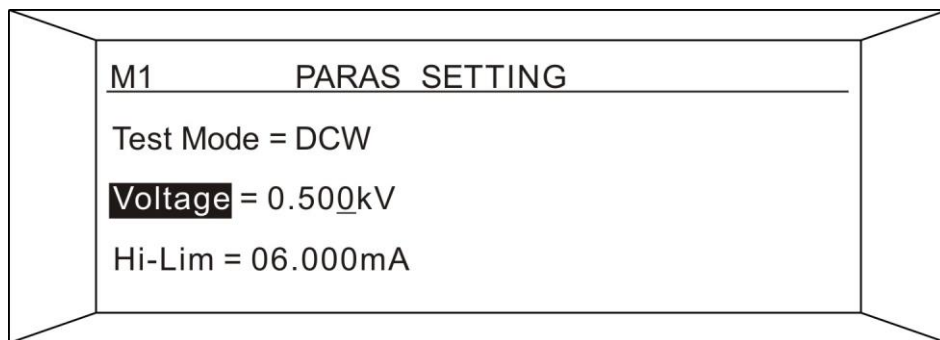


8.8 "TestMode" Set up the interface

Press [Enter] under this interface, and the DCW appears underlined to use the "▲" or "▼" Key to select the test mode. Press [Enter] when the selection is complete. If you want to give up the setting press the [ESC] key to bring up the setting.

2. Test output voltage value setting (AC/DC withstand voltage test and insulation resistance test)

Use the "▲" or "▼" Key to select the Voltage setting in the measurement parameter setting interface, as shown in the following figure:



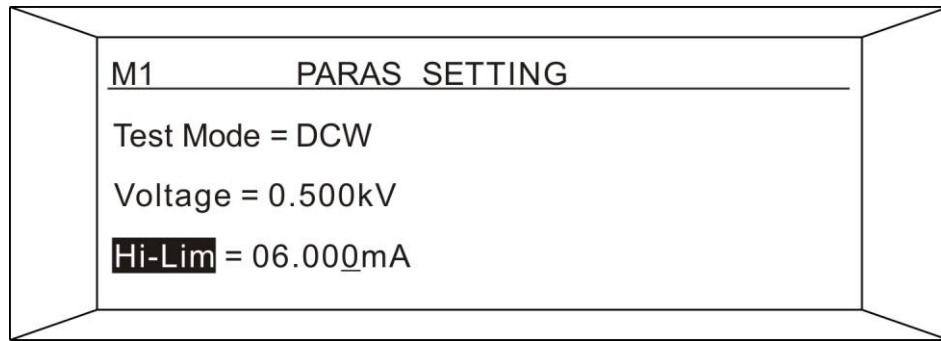
8.9 "Voltage" interface

In this interface press [ Enter ] key, the last bit of voltage value will appear underscore, use "◀" or "▶" Key to select the need to change the number of bits, use "▲" or "▼" Key to set the size of the number of bits. When you're done, press Enter. If you want to give up the setting press the ESC key to exit the setting.

**Note:** If the set voltage value is out of range, the instrument will automatically determine that it is out of range, will automatically restore the set value before the set value.

3. Test current comparator upper limit setting (AC/DC withstand voltage test)

Use the "▲" or "▼" Key to select the "Hi-Lim" settings at the measurement preferences interface, as shown in the following figure:



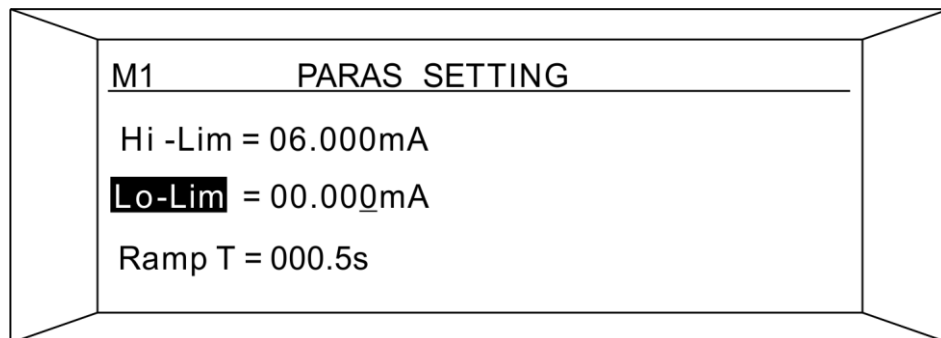
8.10 Withstand voltage test “Hi-Lim” setting interface

In this interface press Enter key, the last of the upper limit value will appear underscore, use “◀” or “▶” Key to select the need to change the number of bits, use “▲” or “▼” Key to set the size of the number of bits. When you are done, press Enter. To unset the settings, press the ESC key to exit the settings.

**Note: If the upper limit setting value is out of range, the instrument will automatically determine that it is out of range, and the setting value will automatically revert to the previous setting value.**

4. Lower limit setting of test current comparator (AC/DC withstand voltage test)

Use the “▲” or “▼” Key to select “Lo-Lim” settings in the measurement preferences interface, as shown in the following figure:



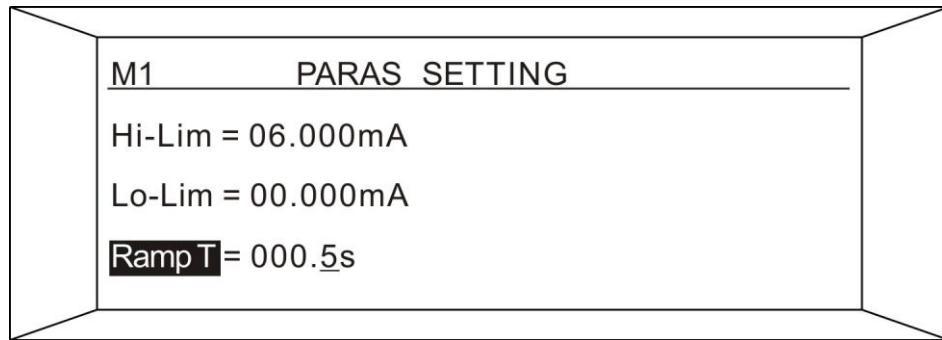
8.11 Withstand voltage test “Hi-Lim” setting interface

In this interface press [Enter] key, the bottom of the lower limit value will appear underlined, that is, you can use “◀” or “▶” key to select the need to change the number of bits, use “▲” or “▼” Key to set the size of the number of bits. When you are done, press [Enter]. If you want to give up the setting press the ESC key to exit the setting.

**Note: If the setting value of the lower limit is not in the range, the instrument will automatically determine that it is not in the range, and will automatically restore the setting value before the setting value.**

5. Voltage rise time setting (AC/DC VOLTAGE WITHSTAND test)

Use the “▲” or “▼” Key on the measurement settings screen to select [Ramp T] settings, as shown in the following figure:



8.12 Withstand voltage test “Ramp T” setting interface

Press [Enter] key under this interface, the last bit of the lower limit value will appear underscore, that is, use “◀” or “▶” Key to select the number of bits that need to be changed, use “▲” or “▼” Key to set the value size of the number. When you are done, press [Enter] to confirm. To unset the settings, press the [ESC] key to exit the settings.

The voltage rise time setting is the value that the output voltage value is set to rise with that time.

For example:

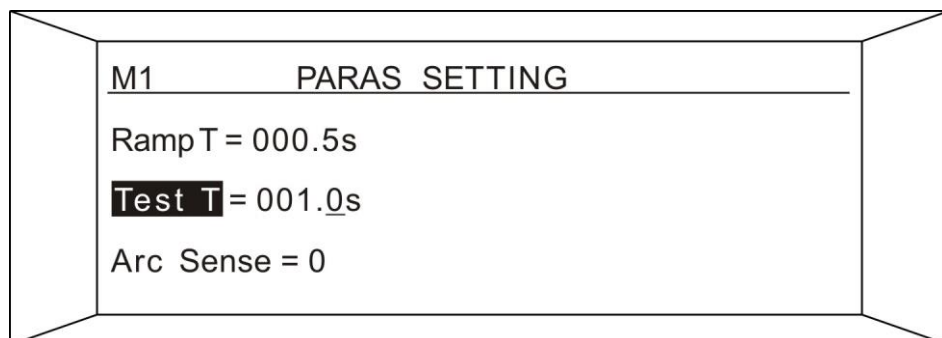
Set output voltage 3.000 KV, need voltage rise rate of 500 V/S;

Calculate out Ramp T =  $3000V / (500V/S) = 6S$ ;

Ramp T is set to 6.0 seconds

#### 6. Voltage withstand test time setting (AC/DC voltage withstand test)

Use the “▲” or “▼” Key to select the Test t setting in the measurement settings screen, as shown in the following figure:



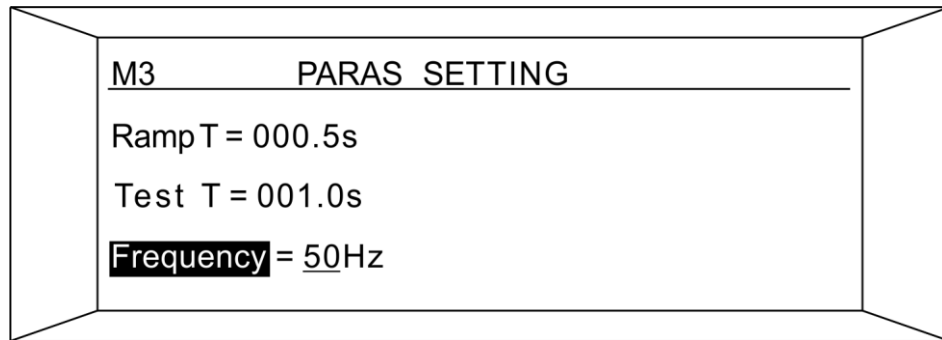
8.13 Withstand voltage test “Test T” setting interface

In this interface press [Enter] key, the bottom of the lower limit value will appear underlined, that is, you can use “◀” or “▶” key to select the need to change the number of bits, use “▲” or “▼” Key to set the size of the number of bits. When you are done, press [Enter]. If you want to give up the setting press the [ESC] key to bring up the setting.

---

## 7. AC output frequency setting (AC withstand voltage test)

Use the “▲” or “▼” Key to select the “Frequency” setting on the measurement settings screen, as shown in the following figure:



8.14 AC withstand voltage test “Frequency” setting interface

In this interface press [Enter] key, under the setting value appears underline, with “▲” or “▼” Key set value. When you are done, press [Enter]. To unset the settings, press the [ESC] key to exit the settings.

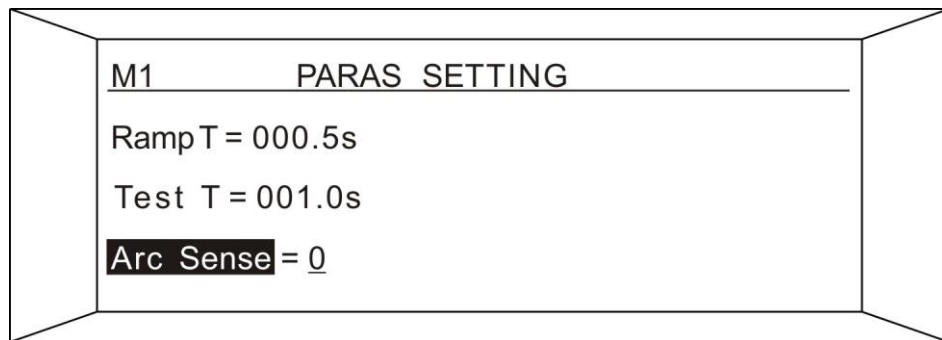
Frequency set options:

50Hz: AC output frequency is 50Hz

60Hz: AC output frequency is 60Hz

## 8. Arc Sensitivity Setting (AC/DC voltage withstand test)

Use the “▲” or “▼” Key to select the “Arc Sense” settings in the measurement settings screen, as shown in the following figure:



8.15 Withstand voltage test “Arc Sense” setting interface

Press the [Enter] key under the interface, underline the set value, and set the value with the “▲” or “▼” Key. Press [Enter] when the setup is complete. Press the [ESC] key if you want to give up the setting.

Arc Sense set options:

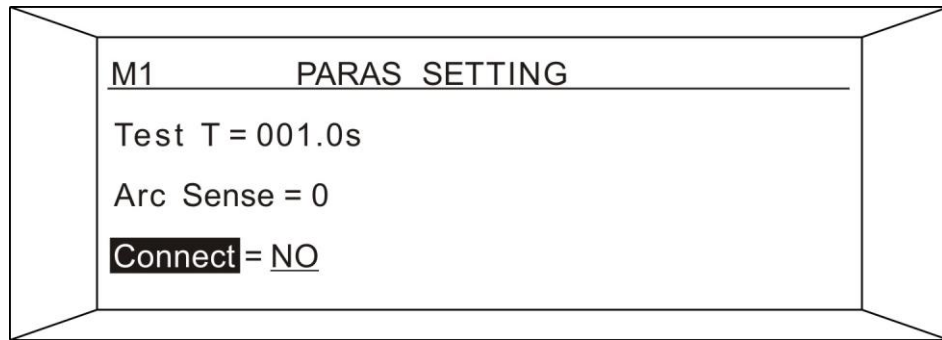
0: Turn off the ARC alarm

1-9: Turn on the ARC alarm function, the higher the number, the higher the sensitivity

## 9. Continuous test function setting (AC/DC voltage withstand test and insulation resistance test)



Use the “▲” or “▼” Key to select the “Connect” settings on the measurement settings screen, as shown in the following figure:



8.16 withstand voltage test “Connect” setting interface

In this interface press [Enter] key, under the setting value appears underline, with “▲” or “▼” Key set value. When you are done, press [Enter] enter. To unset the settings, press the [ESC] key to exit the settings.

Connect set options:

No: turn off the group continuous test function

Yes PASS: Open this group to connect to the next set of tests if the test passes

Yes ALL: Turn on the group in the continuous test function (test results are qualified and unqualified are connected to the next group of tests)

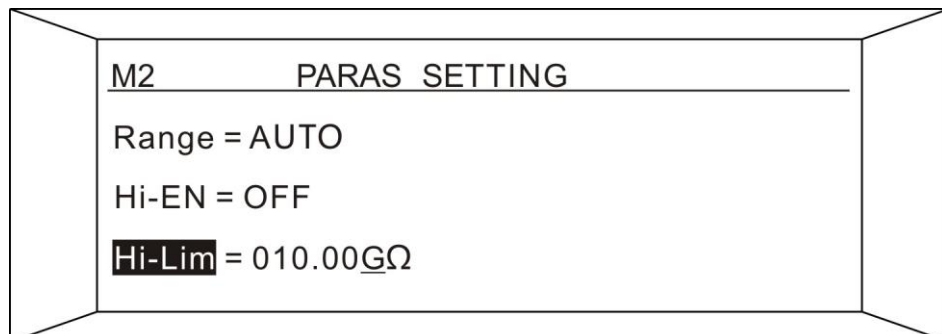
This set of continuous functions is turned on to connect to the next set when the set of tests is complete and conditions are met.

For example, to test the M1 M2 M3 connection, simply turn on the continuous test functions for M1 and M2.

**Note: Up to 3 sets of connection tests.**

10. Test Resistance comparator upper limit setting (insulation resistance test)

In the insulation resistance test mode, the measurement parameter setting interface selects the “Hi-Lim” setting using the “▲” or “▼” Key, as shown in the following diagram:



8.17 Insulation Resistance “Hi-Lim” setting interface

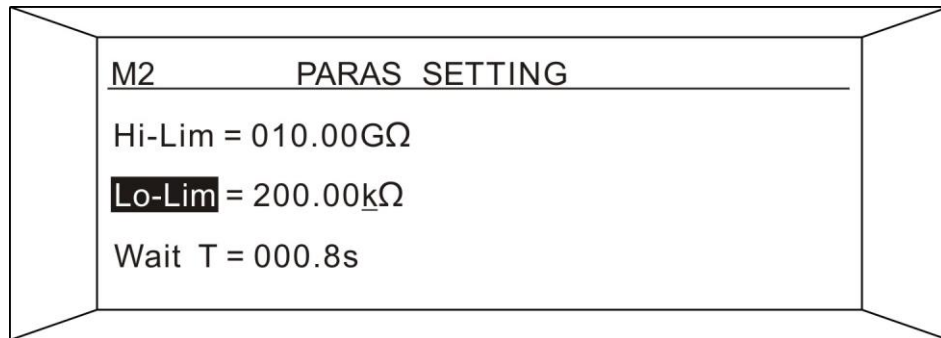
In this interface, press [Enter] key, the last “G” of the upper limit will appear underscore, that is, use “▲” or “▼” Key to select the number of bits need to be changed, use “▲” or “▼”

---

Key to set the value size of the number. You can use the key “▲” or “▼” To set the unit on the “G”, and then press [Enter] to set it. To unset the settings, press the [ESC] key to exit the settings.

**Note: If the upper limit setting value is out of range, the instrument will automatically determine that it is out of range, and the setting value will automatically revert to the previous setting value.**

11. Set the lower limit of the test resistance comparator (Insulation Resistance Test)  
In the insulation resistance test mode, the measurement parameter setting interface selects “Lo-Lim” settings using the “▲” or “▼” Key, as shown in the following diagram:

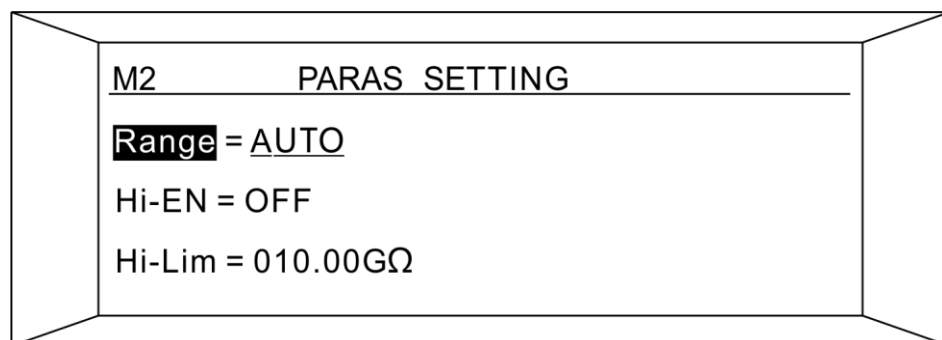


8.18 Insulation Resistance “Lo-Lim” setting interface

In this interface press [Enter] key, the last “k” of the upper limit value appears underscore, that is, you can use the “◀” or “▶” Key to select the need to change the number of bits, with the “▲” or “▼” Key to set the value size of the number. In “k” for the above can use “▲” or “▼” Key to set the unit, set the completion of the press [Enter] to determine. To unset the settings, press the [ESC] key to exit the settings.

**Note: If the setting value of the lower limit is not in the range, the instrument will automatically determine that it is not in the range, and will automatically restore the setting value before the setting value.**

12. Test Range Setting (insulation resistance test)  
In Insulation Resistance Test Mode, the measurement settings interface uses the “▲” or “▼” Key to select the “Range” settings, as shown in the following illustration:



8.19 Insulation Resistance “Range” setting interface

Press the [Enter] key on this screen to select the quantum with the “▲” or “▼” Key. Press [Enter] when the selection is complete. If you want to give up the setting press the [ESC] key

to bring up the setting.

Range has the following options:

AUTO: automatic measuring range mode, start measuring from 30M $\Omega$  range by default

300k $\Omega$ : Measure from 300k $\Omega$  range

3M $\Omega$ : Measure from 3M $\Omega$  range

30M $\Omega$ : Measure from 30M $\Omega$  range

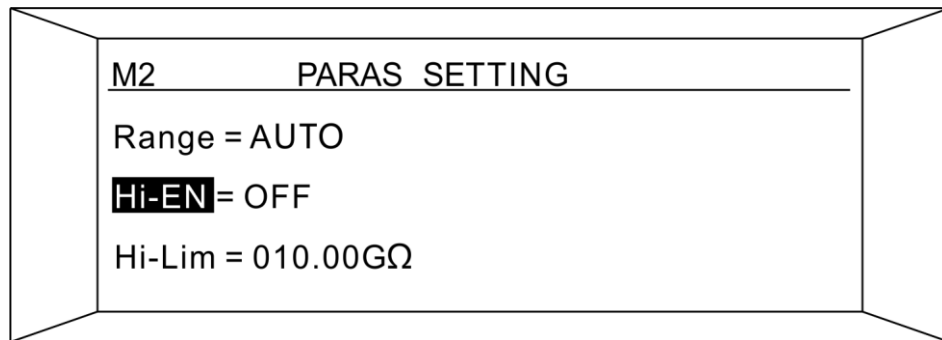
300M $\Omega$ : Measure from 300M $\Omega$  range

100G $\Omega$ : Measure from 100G $\Omega$  range

**Note: When the range setting is not [AUTO], the range is automatic. Just start the measurement at the selected range by default.**

13. Resistance comparator upper limit enable setting (insulation resistance test)

In the insulation resistance test mode, the measurement parameter setting interface uses the “▲” or “▼” Key to select the “Hi-EN” setting as shown below:



8.20 Insulation Resistance “Hi-EN” setting interface

Press the [Enter] key on this screen to select the quantum with the “▲” or “▼” Key. Press [Enter] when the selection is complete. If you want to give up the setting press the [ESC] key to exit the setting.

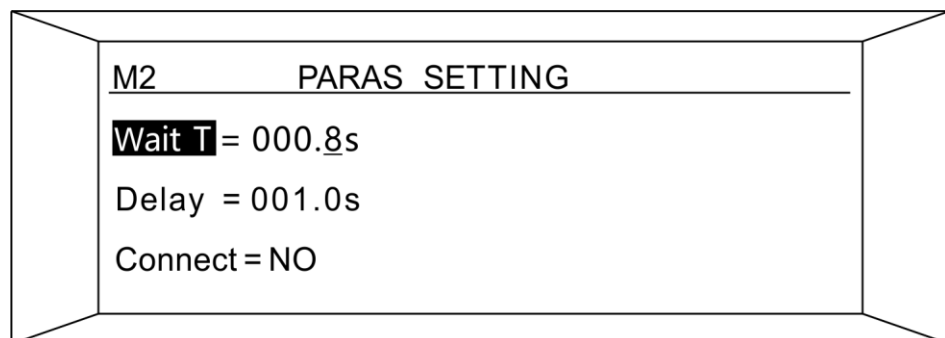
HI-EN has the following options:

OFF: turn off comparator upper limit

No: open comparator upper limit function

14. Wait time setting (insulation resistance test)

In the insulation resistance test mode, the measurement parameter setting interface uses the “▲” or “▼” Key to select the “Wait T” setting, as shown below:



8.21 Insulation Resistance “Wait T” setting interface

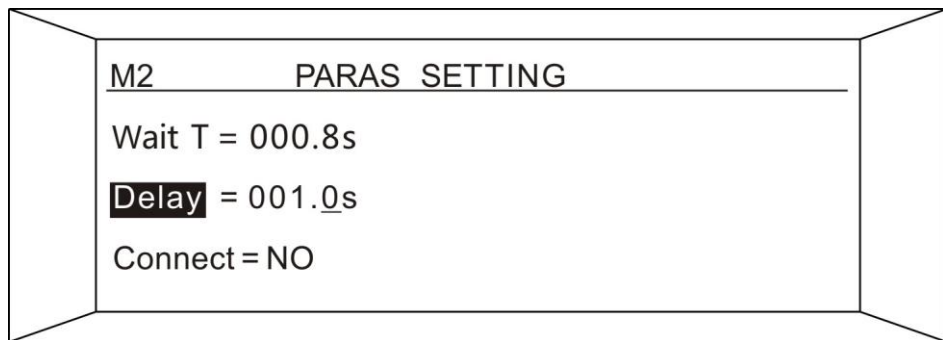
---

In this interface press [Enter] key, the last bit of time will appear underscore, use “◀” or “▶” Key to select the need to change the number of bits, use “▲” or “▼” Key to set the value size of the number. When you are done, press [Enter]. To unset the settings, press the [ESC] key to exit the settings.

**The insulation resistance wait time is turned off between the start of the test and the wait time of the comparator.**

15. Delay Time Setting (insulation resistance test)

In the insulation resistance test mode, the setting interface uses the “▲” or “▼” Key to select the [Delay] setting as shown in the following diagram:



8.22 Insulation Resistance “Delay” setting interface

In this interface, press [Enter] key, the last bit of time will appear underscore, that is, use “◀” or “▶” key to select the number of bits need to change, use “▲” or “▼” Key to set the value size of the number. When you are done, press [Enter] to confirm. To unset the settings, press the [ESC] key to exit the settings.

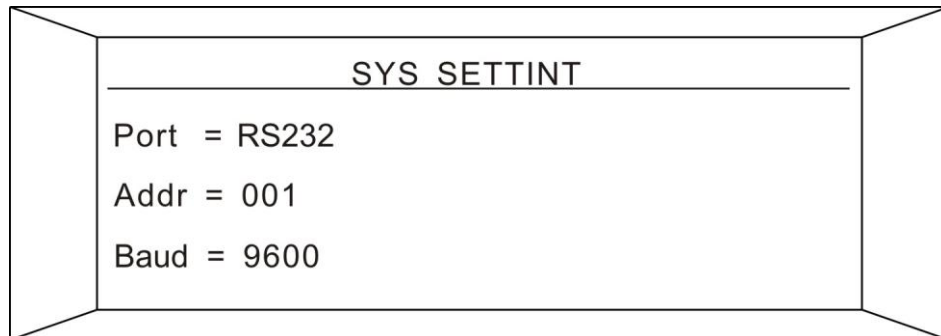
**Note: In the delay time, as long as the measured resistance value does not conform to the value set by the comparator, the instrument will stop the test and output the unqualified signal.**

---

# Chapter 9 System parameter setting

## 9.1 System Specification

In the test parameter setting interface press “Set” key, that is to enter the system parameter setting interface, as follows:

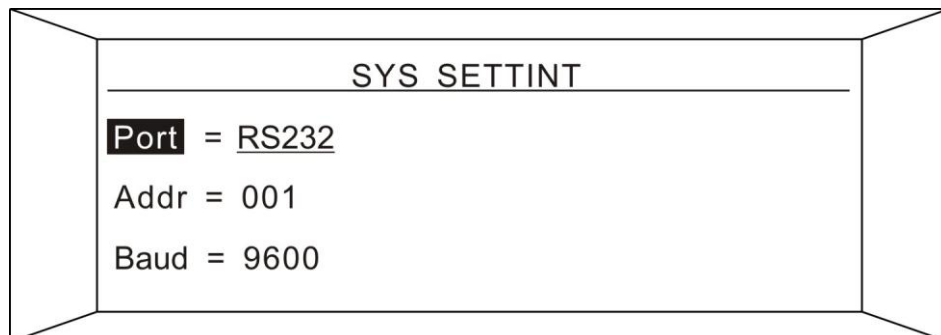


9.1 System parameter setting interface

## 9.2 System parameter setting

### 1. Communication Port Selection

Press the “▲” or “▼” Key to select what you want to set, as shown below.



9.2 “Port” setting interface

Press [Enter] key under this interface, RS232 can appear underline to use “▲” or “▼” Key to choose communication mode. Press [Enter] when the selection is complete. If you want to give up the setting press the [ESC] key to bring up the setting.

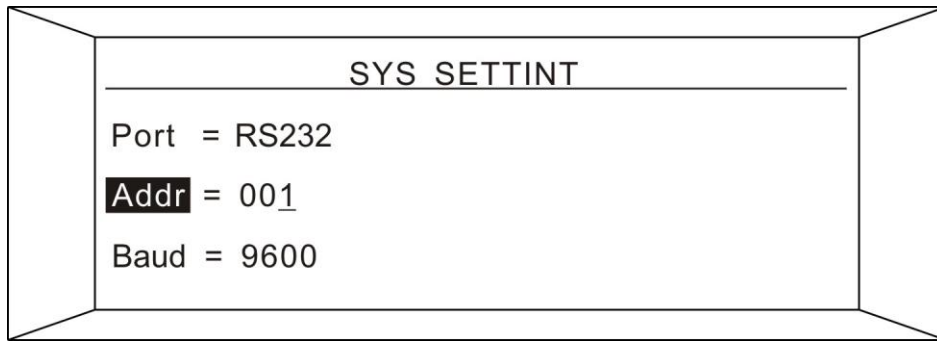
Port setting options:

RS232: Open the RS232 communication port

RS485: Open the RS485 communication port

### 2. Instrument Communication Address Setting

Press the “▲” or “▼” Key to select what you want to set, as shown below.



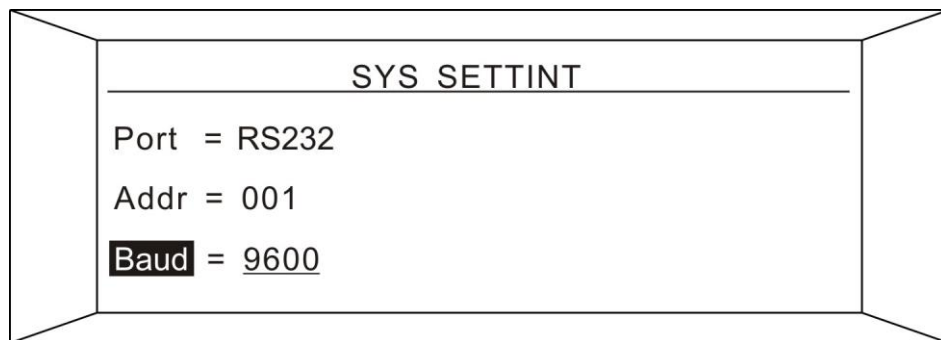
9.3 "Addr" setting interface

Press [Enter] under this interface, the last bit of the address will appear underlined, use the "◀" or "▶" Key to select the number of bits that need to be changed, and use "▲" or "▼" key to set the value size of the bit. When you are done, press [Enter] to confirm. To unset the settings, press the [ESC] key to exit the settings.

**Note: Address set range 001 ~ 255**

### 3. Instrument Communication Baud Rate Setting

Press the "▲" or "▼" Key to select what you want to set, as shown below.



9.4 "Baud" setting interface

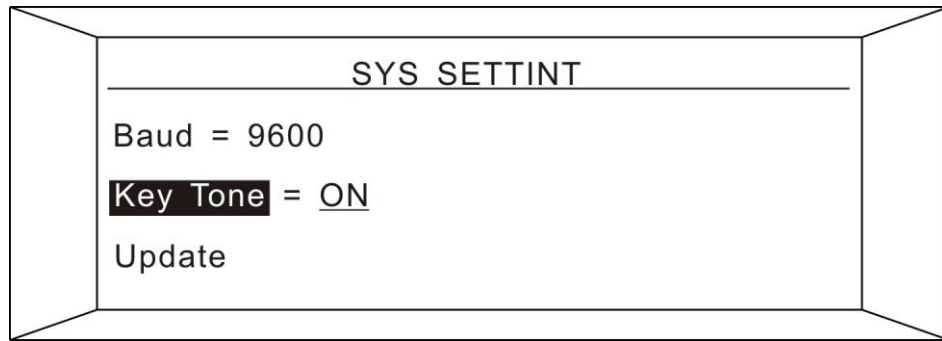
Under this interface press [Enter] key, the Baud rate setting value will appear underline, use "▲" or "▼" Key to select the desired baud rate. When you are done, press [Enter]. To unset the settings, press the [ESC] key to exit the settings.

Baud setting options:

- 9600: Communication Baud rate is 9600;
- 19200: Communication Baud rate is 19200;
- 38400: Communication Baud rate is 38400;

### 4. Key tone settings

Press the "▲" or "▼" Key to select what you want to set, as shown below.



9.5 "key Tone" setting interface

In this interface press [Enter] key, key switch set value will appear underline, with \* or \* Key to select the required baud rate. When you are done, press [Enter]. To unset the settings, press the [ESC] key to exit the settings.

Key Tone setting options:

OFF: Turn off button sound;

No: Turn on button sound;

---

# Chapter 10 User Zeroing calibration

Before leaving the factory, the instrument has been calibrated according to the relevant verification regulations of the national standards, and the precision of the instrument and the instrument fully conforms to the national standards. It is suggested that the instrument needs to be calibrated at least once a year, calibration standard instrument accuracy must meet the corresponding requirements to ensure the accuracy of the instrument.

## 10.1 User zeroing instructions

Press the [Set] key at the system parameter setting meeting to enter the user reset interface, as follows:

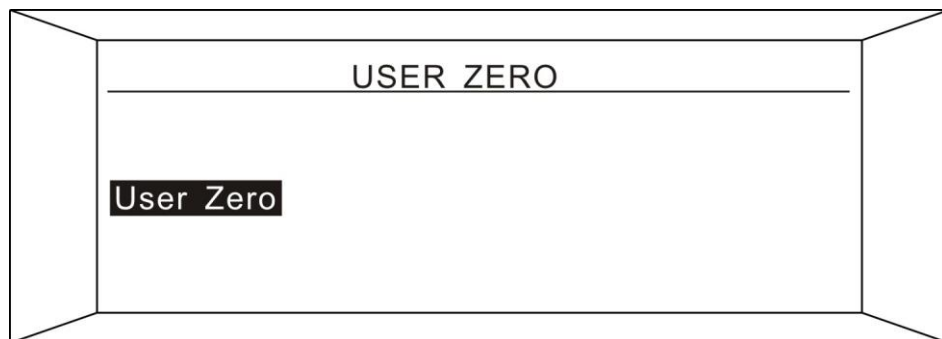


Figure 10.1 User Zero interface

**Note:** When using the user zero function, the test line must be pulled out to ensure the correctness of calibration.

## 10.2 Use the user zero function

In the user zero interface, press the [Set] key to start the user zero function, as follows:

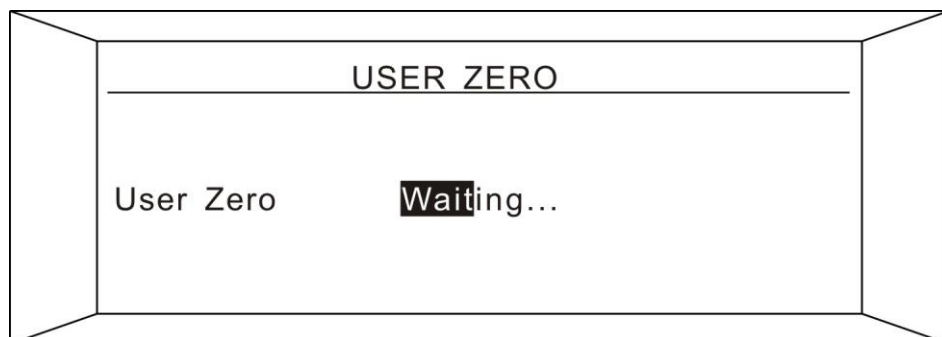


Figure 10.2 User Zero interface

When the “User Zero OK” appears, the zeroing is success and the [ESC] button is pressed to return to the test interface. The zeroing success screen looks like this:



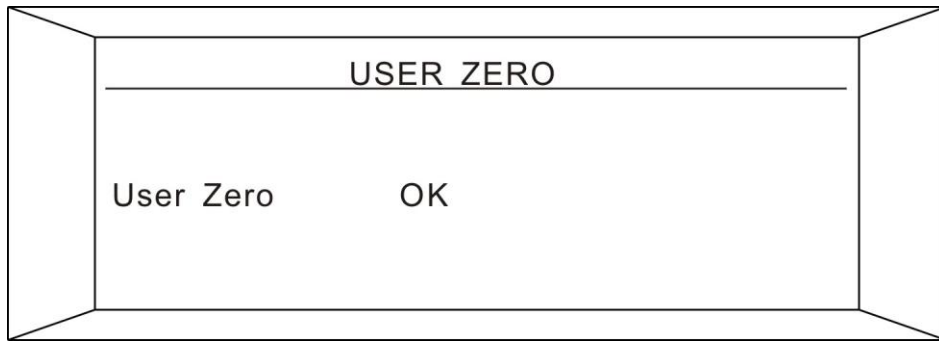


Figure 10.3 User Zero success screen

---

# Chapter 11 Maintenance Guide

## 11.1 Routine maintenance

1. The test instrument should be used in a well-ventilated, dry, dust-free and electromagnetic interference-free environment.
2. If the tester is not used for a long time, it should be powered on regularly. Usually once a month electrify, electrify time not less than 30 minutes.
3. After working for a long time (8 hours) , power off for more than 10 minutes to keep the instrument in good working condition.
4. The test line may have bad contact or open circuit phenomenon after long-term use, it should be repaired regularly.

## 11.2 Simple fault handling

Malfunctions	Processing method
Boot, no display, the key does not respond	Please check the power supply is normal, the fuse on the back panel is fused, if fused, please replace the fuse.
After starting, the high-voltage indicator is not on, but there is a test voltage	The high-voltage indicator lamp is broken.
After the test failed, the alarm light did not come on	The alarm light is out.
After starting, the voltage is normal but no current output	Please check whether the test line is open, the object under test is not in good contact or the object under test is open.

If there is a failure can not be eliminated in time, please contact us as soon as possible, we will provide you with timely services.

## 11.3 Quality Assurance

The company guarantees that the products manufactured are subject to strict quality assurance. The warranty period is two years. Any manufacturing defects or faults occurring during this period will be repaired free of charge.

For the user to modify the circuit, function or more than the quality guarantee period of the product, as the actual situation of the charge for maintenance.